

Caterpillar Digital Voltage Regulator (CDVR) Introduction and Specifications

Prepared by Service Training

<https://psmktg.cat.com/srvtrng/>

Foreword

This presentation was prepared by Caterpillar Service Training to be a training overview of the CDVR for Caterpillar generator set service personnel. This presentation provides comparisons to the previous design, DVR, and includes information pertaining to the removal of a DVR and replacement with a new CDVR. As always, the proper service information for the regulators in SIS should be used for the latest specific details for operation, adjustments, programming and troubleshooting. Please E-mail comments about this overview presentation to Todd Roth at roth_b_todd@cat.com. Thank You!

Compatibility – Products Affected

The following product's standard configuration or available options will be affected. The change will affect PMG generators that have the CDVR as standard or option. Generators that do not have an option for the DVR will not be affected.

Model	Current Price Lists	Changes to Price List
G3306	EPG	No changes
G3406, G3412	PKG	Removed DVR with KVAR/PF option CDVR option includes KVAR/PF control
3306, 3406, 3456, 3412	PKGG - Griffin Source	Removed DVR with KVAR/PF option CDVR option includes KVAR/PF control
3306, 3406, 3412	PKGI - Larne Source	
3406E, 3456	PKGI - Larne Source	No changes
3406, 3412	PKGT - Tianjin Source	Removed DVR with KVAR/PF option CDVR option includes KVAR/PF control

Compatibility – Products Affected Con't.

The following product's standard configuration or available options will be affected. The change will affect PMG generators that have the CDVR as standard or option. Generators that do not have an option for the DVR will not be affected.

Model	Current Price Lists	Changes to Price List
3508, 3512, 3516 G3508, G3512, G3516	PKG	CDVR replaces DVR (LV, MV) CDVR replaces KCR 760 & KCR 65-12B (HV).
3508, 3512, 3516, G3516B	PMs	HV deletion: KCR 760 & KCR 65-12 B Auto Manual Control for KCR regulators, Max Min exciter, Auto Manual Voltage Control, RFI Suppression, Motor Operated Potentiometer.
G3516B	PKG, CHP	
G3520B, G3520C	PKL, CHL	
3508 HV Options	PKG	HV option deleted based on low sales
G3508, G3512, G3516	EPG	VR6 is standard with SE generators CDVR is standard with PM generators

Other CDVR Production Information

- The CDVR will replace DVR for low and medium voltage generators and will also replace KCR 760 & KCR 65-12B for high voltage generators. A follow-up announcement will be sent that details product changeover on all affected products.
- The CDVR will be used in all EPG products currently available with a standard or optional CDVR and with high voltage applications where analog regulators are standard with current product.
- 3500 SE Generators will be shipped with a VR-6
- 3500 PM Generators will be shipped with a CDVR

CDVR starts production January 2004



**Digital Voltage
Regulator or “DVR”**



**January
2004
Transition**



**Caterpillar Digital Voltage
Regulator or “CDVR”**

DVR from 1994-2003



- Previous design pictured
- Called the “DVR” or “Digital Voltage Regulator”
- Manufactured by Magnetek-Century
- Will be discontinued
- Replaced with the new “Caterpillar Digital Voltage Regulator” or “CDVR”
- Six part numbers were used to accommodate SE & PM, 120, 240, and 480 VAC sensing requirements

Caterpillar Digital Voltage Regulator



- New design pictured
- Called the “Caterpillar Digital Voltage Regulator” or abbreviated “CDVR”
- Made by Basler Electric
- Will be used on Caterpillar generator sets and will replace the “DVR”
- January 2004 Production
- Only One Part Number is needed for all applications
- KVAR/PF control included

CDVR Publications

- Available on Service Information System (SIS)
 - RENR7941 Specifications System Operation Testing & Adjusting Guide
 - “CDVR PC Software” is available on SISweb in the Flash File download section or on the monthly SIS subscription Flash File CD ROM.
- Available on Electronic Media Center
 - LEHE3225 Specifications Sheet
 - LEXE3226 November 2003 Product News

Part Numbers

- Cat Digital Voltage Regulator (CDVR) - 235-5725
- Connector Part Numbers
 - P6 plug: 234-1856, P6 seal 246-7013.
 - P9 plug: 234-1857, P9 seal 246-7014.
 - P12 plug 234-1858, P12 seal 246-7015.
 - P6, P9 and P12 Pins : 244-0452.
- Planned part number releases:
 - Crimping tool: 239-5260.
 - Extraction tool: 246-8636.

A Brief Look...



- There is no touch pad or display for programming
- PC programming only
- PC software is on SIS
- RS-232 PC connection
- No screw terminals
- 3 Molex connectors
- Bolt pattern like the DVR
- Fault LED Indicator

Why a new Caterpillar Regulator?

- DVR was designed in early 1990's...
 - 1990's technology has fewer features
 - Internal components are becoming obsolete
 - DVR designed for fewer applications
 - Not cost effective to improve present design
- The CDVR has improved transient performance, added standard features such as VAR & PF control, and expanded flexibility for optimizing performance to individual customer applications.

Features

- Microprocessor control of three standard modes
 - Automatic Voltage Regulation (AVR)
 - Power Factor Regulation (PF)
 - Reactive Power Regulation (VAR)
- Programmable stability settings
- Soft start control with an adjustable time setting in AVR control mode
- Dual Slope Under Frequency (volts/Hertz) regulation

Features

- Three-phase or single-phase generator voltage (RMS) sensing/regulation in AVR mode
- Single-phase generator current sensing for regulation purposes
- Field current and field voltage sensing
- Five contact sensing inputs for system interface
- One common LED for visual indication of Alarm and Shutdown fault conditions
- Ten generator protective functions

Features

- Fault Shutdown Driver and Alarm Output Driver for indication of Alarm and Shutdown fault conditions
- Generator paralleling with reactive droop compensation and reactive differential compensation
- Line drop compensation
- Remote communication interface via CAN 2.0B or RS-232
- UL 508A Listed and CE certified

Modes of Operation Defined

- Automatic Voltage Regulation (AVR)
- Reactive Power (VAR) Regulation
- Power Factor (PF) Regulation

Automatic Voltage Regulation Mode

- AVR mode regulates the RMS generator output voltage. The regulator senses the generator output voltage through the sensing leads and then adjusts the dc output excitation current to the generator exciter field. This excitation current maintains the generator terminal voltage at the regulation setpoint.
- This is the basic function of any voltage regulator on a standalone generator set
- AVR mode is the default operating mode and can be disabled by a switch input or the J4 port with CDVR PC Software.

VAR Control Mode

- Reactive or VAR mode regulates “Volt-Amps Reactive” when paralleling with an infinite bus. The CDVR calculates generator VARs from output voltage and droop CT current quantities and adjusts the excitation current to maintain VARs at the programmed setpoint. VAR mode and PF mode are mutually exclusive modes that both work in conjunction with AVR mode.
- VAR mode is enabled by a switch input or the CDVR PC Software. VAR is adjustable from 100 percent absorb to 100 percent generate.
- Typically used when paralleled with utility.

Power Factor Control Mode

- PF mode regulates Power Factor when paralleling with an infinite bus. The CDVR calculates PF using the sensed output voltage and current and then adjusts the dc excitation current to maintain PF at the programmed setpoint. Again, VAR mode and Power Factor mode are mutually exclusive modes that both work in conjunction with AVR mode.
- PF mode is enabled by a switch input or the J4 port with CDVR PC Software. PF setpoint is adjustable from 0.6 lag and 0.6 lead. .
- Typically used when paralleled with utility.

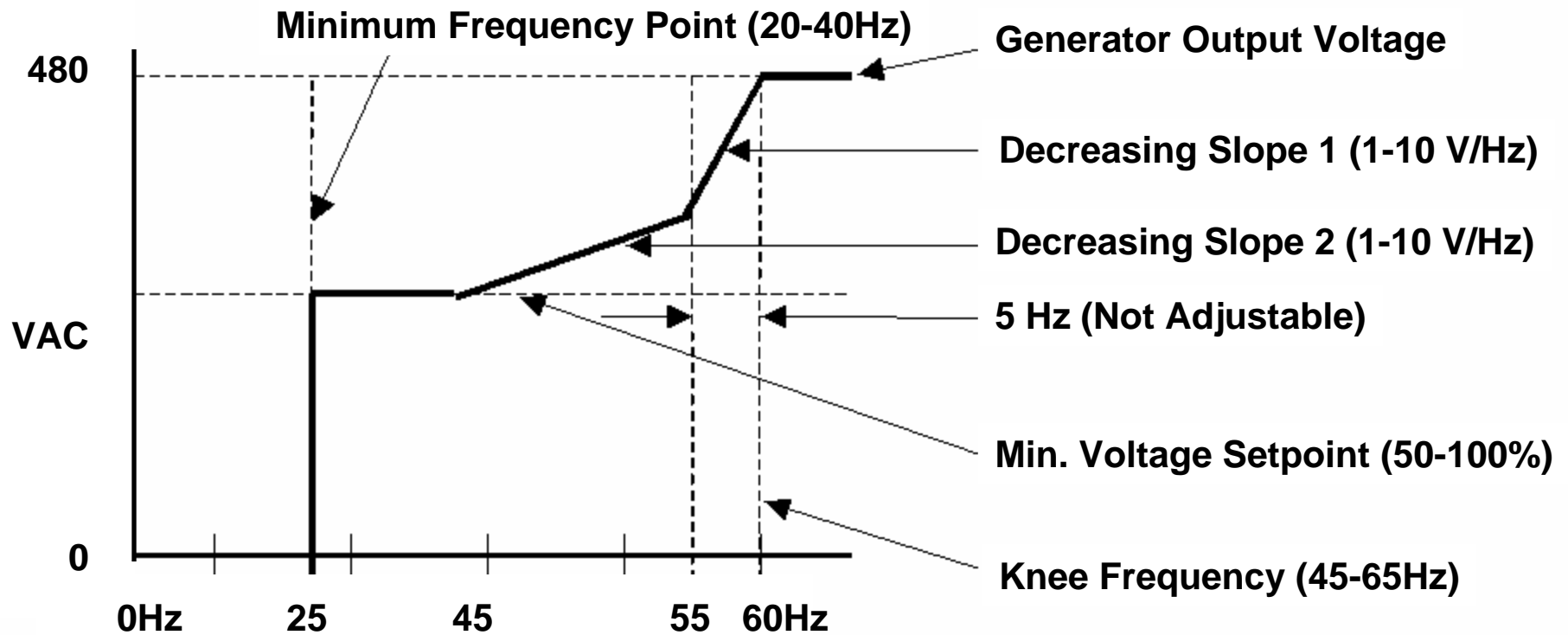

Regulation Characteristic. Below the **Knee Frequency**, the generator voltage follows a decreasing slope based on generator frequency. When generator frequency is between the Knee Frequency and Knee Frequency minus 5 hertz, voltage follows **Slope 1**. When generator frequency is between the Knee Frequency minus 5 hertz and the Underfrequency Point, voltage follows **Slope 2** down to the **Minimum Voltage Setpoint**. When generator frequency is below the **Minimum Frequency Point**, excitation is removed. Programming Decreasing Slope 2 is optional.

10 CDVR Protective Functions

- Generator Overvoltage
- Generator Undervoltage
- Loss of Excitation
- Instantaneous Field Overcurrent
- Over Excitation
- Loss of Sensing Voltage
- Diode Fault Monitor
- Internal CDVR Processor Watchdog Failure
- Internal CDVR Memory Failure
- Fault Reset Switch Closed Too Long

General Specifications

- Voltage Regulation:
 - $\pm 0.25\%$ from no load to full load
- Temperature Drift:
 - Less than $\pm 1\%$ for a 40°C (72°F) change over the ambient operating temperature range.
- Regulator response time:
 - Maximum of 10 milliseconds.
- Variable Sense Range:
 - 90 to 600 volts.
- Control Power:
 - 24Vdc Supply (18 to 30Vdc, 5VA)

General Specifications

- Regulator Filtering:
 - THF 3% per IEC34-1
 - TIF of 50 NEMA MG1-22.43
- Harmonic Tolerance:
 - 0.5% Voltage regulation with up to 40% THD
- Power Dissipation:
 - 55W Maximum
- Weight:
 - 1.47 kg (3.24 lbs.)

General Specifications

- Regulator sensing:
 - True RMS 3-phase sensing is standard. Single phase sensing is available.
- Configurable Volts/Hz Regulation Characteristic
 - Two slope ranges adjustable from 1 to 10 V/Hz. See Regulation Characteristic Illustrations.
- Fine voltage adjust range:
 - $\pm 10\%$ Maximum of regulator sensing voltage.
- Regulator voltage gain (line loss compensation)
 - Adjustable from 0 to 10%.

General Specifications

- Reactive droop adjustment:
 - Adjustable from 0 to 10%.
- Fault detection and identification:
 - Diagnostics identify operation outside of programmed limits. Specific fault information is available after the unit has been powered down.
- Over Excitation protection:
 - Shuts off generator output when excitation current exceeds normal operating currents for 10 seconds or instantaneous shut-off if output current exceeds approximately 28 Amperes.

General Specifications

- Voltage Regulation Rating
 - 120 to 15000 VAC
- Generator Excitation Type
 - PM – Permanent Magnet
 - SE – Self Excited
 - AREP – Auxiliary Winding Capable
- AC Input Power
 - Three phase, 80 to 264 VAC, 50 to 400 Hz, 1150VA
 - Single phase, 100 to 280 VAC, 50 to 400Hz, 1900 VA

General Specifications

- Output Power Maximum Continuous:
 - 12 Amps DC @ 63VDC
 - 10 Amps DC @ 125 VDC
- Output Power Maximum Forcing (10 seconds):
 - 25 Amps DC @ 125 VDC
 - 20 Amps DC @ 250 VDC
- AC Sensing Voltage:
 - True RMS three phase or single phase, 90 to 600 VAC, maximum 1 VA per phase burden.

General Specifications

- Reactive Voltage Droop circuit:
 - 5 Amp Current Transformer, maximum 1 VA burden
 - Regulator has internal CT burden resistor
- Exciter Field Resistance Range
 - 3 Ohms minimum, 39 ohms maximum

Environmental Specifications

- Operating Temperature:
 - -40°C to 70°C (-40°F to 158°F)
- Storage Temperature:
 - -40°C to 85°C (-40°F to 185°F)
- Relative Humidity:
 - 95% non-condensing 30°C to 60°C
- Salt Fog:
 - 5% for 48 hours at 38°C (100°F) at 115% of the nominal operating voltage

Environmental Specifications

- Vibration:
 - 4.5G (peak) 18-2000Hz in 3 perpendicular planes
- Shock:
 - Withstands up to 20 g's in three mutually perpendicular planes.
- Certifications:
 - CE Approved
 - UL 508A Recognized
 - CSA Listed
 - Meets MIL STD 461C

Caterpillar Digital Voltage Regulator (CDVR) Wiring Connections

Prepared by Service Training

<https://psmktg.cat.com/srvtrng/>

Regulator Connectors and LED

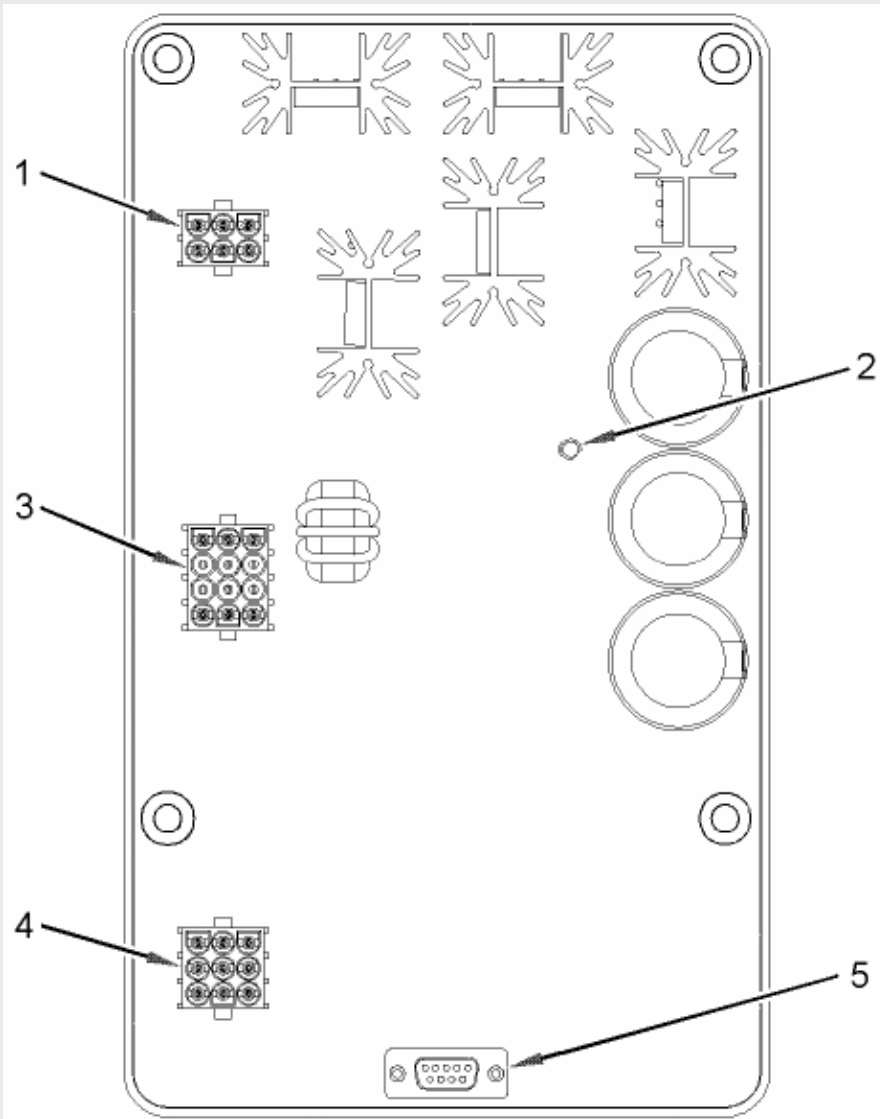

- (1) 6-pin connector "P6"
- (2) LED Indicator
- (3) 12-pin connector "P12"
- (4) 9-pin connector "P9"
- (5) 9-pin D-sub Connector "J4"

Note: Items 1, 3 & 4 are Molex brand Connector plugs

P6 connector pin numbering

Connector "P6"

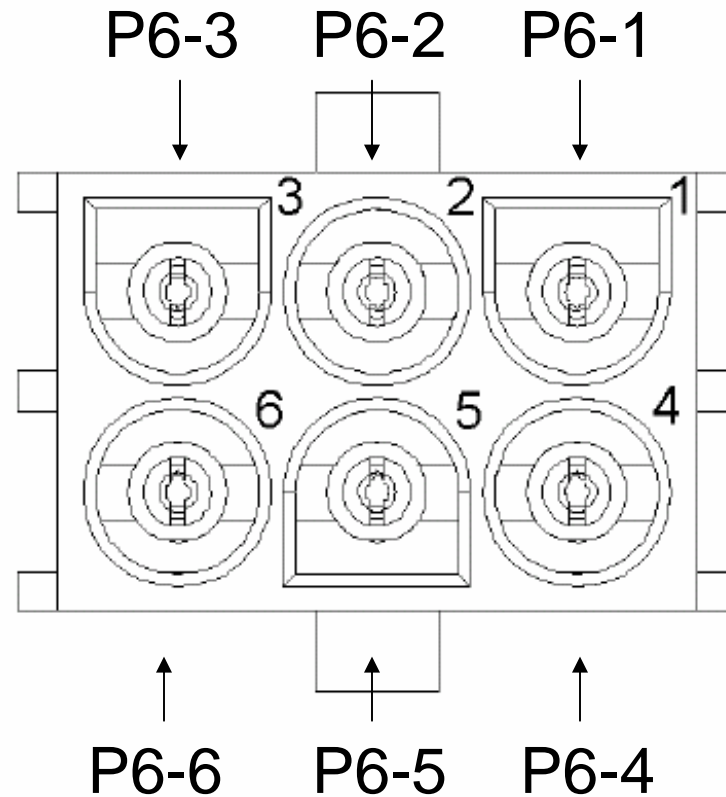

View as looking at P6 on the regulator plug

P6 Wiring

P6 Terminal Functions	
Terminal	Function
P6-1	Power Input
P6-2	Power Input
P6-3	Power Input
P6-4	F-
P6-5	F+
P6-6	Chassis Ground

- Pins 1, 2 & 3: AC power inputs from either SE or PM stator winding
- Pins 4 (-) & 5 (+): DC field voltage output to the generator exciter stator
- Pin 6 should be hard-wired to earth ground with at least a 14 AWG copper wire

P9 connector pin numbering

Connector "P9"

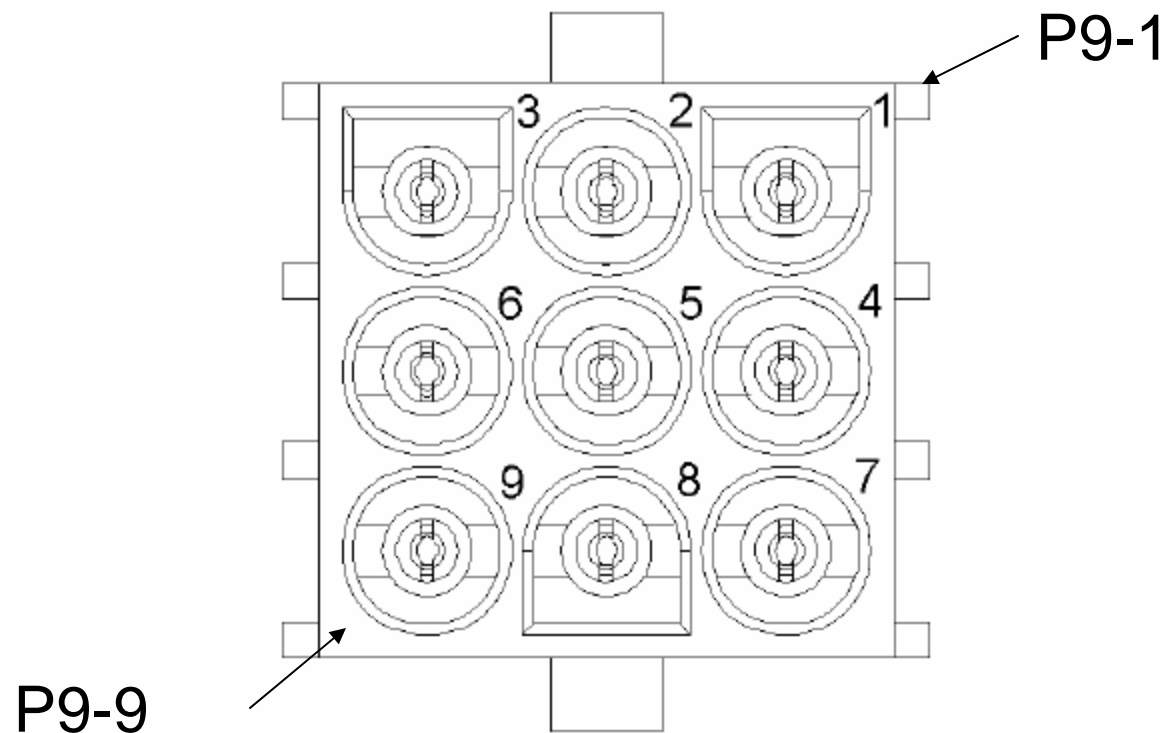

View as looking at P9 on the regulator plug

P9 Wiring

P9 Terminal Functions	
Terminal	Function
P9-1	CANbus - High
P9-2	CANbus - Low
P9-3	CANbus - Drain (Shield)
P9-4	Contact Sense - Lower
P9-5	Contact Sense - Raise
P9-6	Contact Sense - Common
P9-7	Contact Sense - Excitation Disable
P9-8	Contact Sense - Fault Reset
P9-9	Contact Sense - Var/PF Enable

- Pins 1, 2 & 3: CANbus data link connections
- Pins 4, 5 & 6: Raise and Lower connections for voltage level adjustments in AVR mode, KVAR level in KVAR mode and P.F. level adjustment in P.F. Mode
- Pin 7: Excitation Disable of field voltage to exciter stator
- Pin 8: Fault Shutdown Reset
- Pin 9: VAR/PF mode enable

P12 connector pin numbering

Connector "P12"

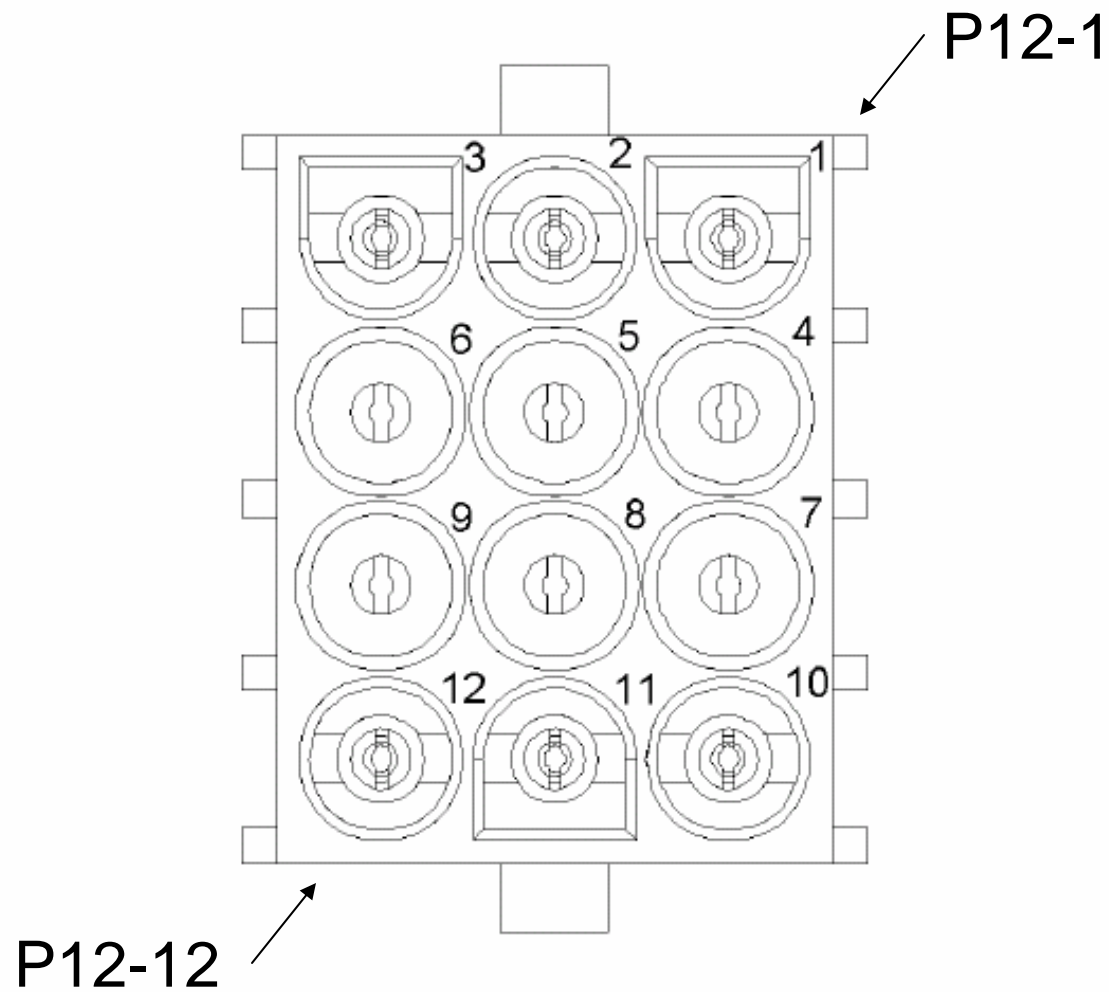

P12 Wiring

P12 Terminal Functions	
Terminal	Function
P12-1	B-phase generator current sensing (CT1)
P12-2	B-phase generator current sensing (CT2)
P12-3	±10 DCV Input (B), -
P12-4	Alarm Output Driver
P12-5	Fault Shutdown Driver
P12-6	±10 DCV Input (A), +
P12-7	18 to 30 V Control Power Input (B-)
P12-8	18 to 30 V Control Power Input (B+)
P12-9	Driver Supply (50)
P12-10	Generator Voltage Sensing - C
P12-11	Generator Voltage Sensing - B
P12-12	Generator Voltage Sensing - A

- Pins 1 & 2: droop CT input
- Pins 3 & 6: +/-10 DCV in
- Pin 4: Alarm output
- Pin 5: Fault SD output
- Pins 7 & 8: 24VDC Input
- Pin 9: Alarm and Fault Shutdown Supply Driver
- Pins 10, 11, & 12: Generator AC voltage sensing phases “C”, “B”, and “A” respectively.

J4 connector pin numbering

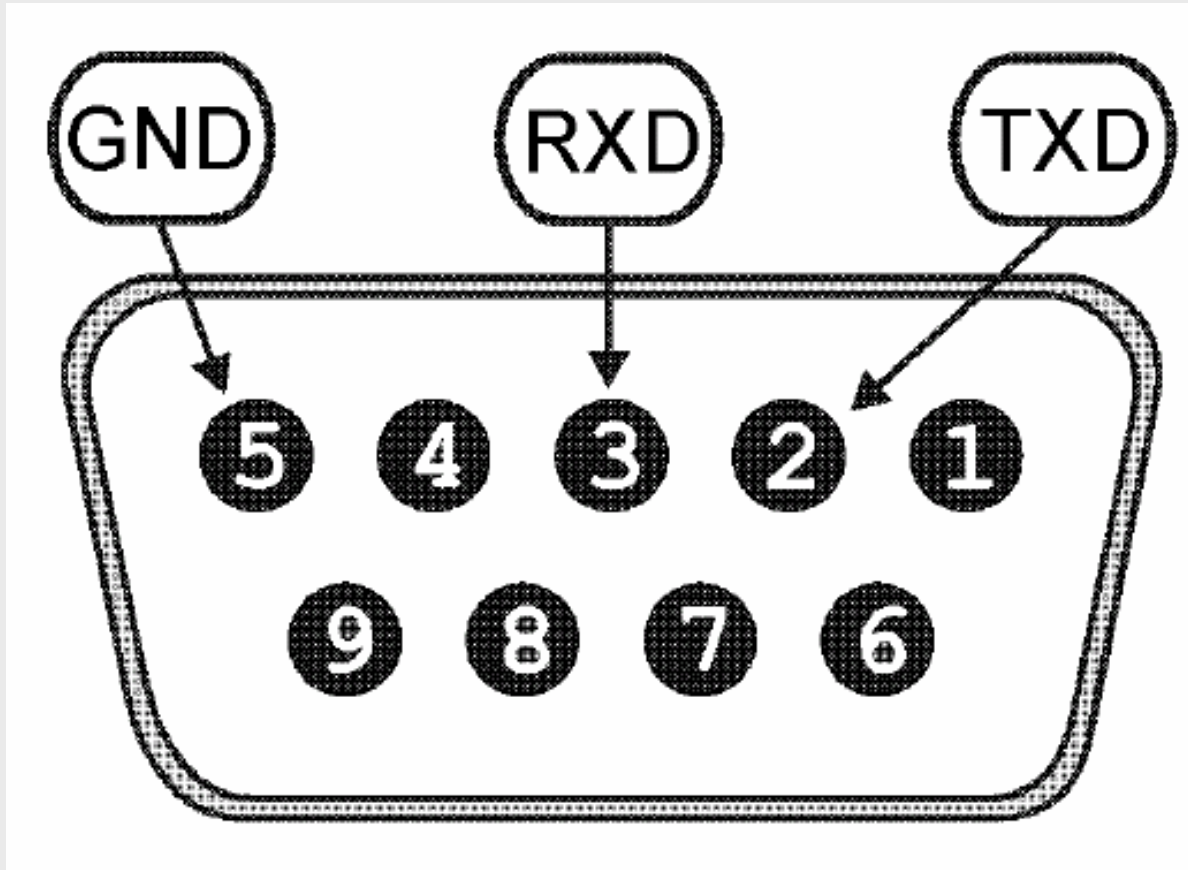

The digital voltage regulator has the capability to communicate with a personal computer or programmable logic controller. The J4 connector of the digital voltage regulator provides an RS-232 port necessary for communication. Pin locations and numbers are shown above.

J4 RS-232 Wiring

Pin	Function
1	-
2	Transmit Data
3	Receive Data
4	-
5	Signal Ground
6	-
7	-
8	-
9	-

The J4 RS-232 port is a 9-pin connector including a pins for Receive, Transmit, common Signal Ground. The common signal ground is NOT a bonding ground and should not be grounded to the case or frame. It is to be connected to the RS-232 device Signal Ground connection point. Cable length should be limited to 15 m (50 ft) maximum for the RS-232 signal wiring.

Example PMG Diagram

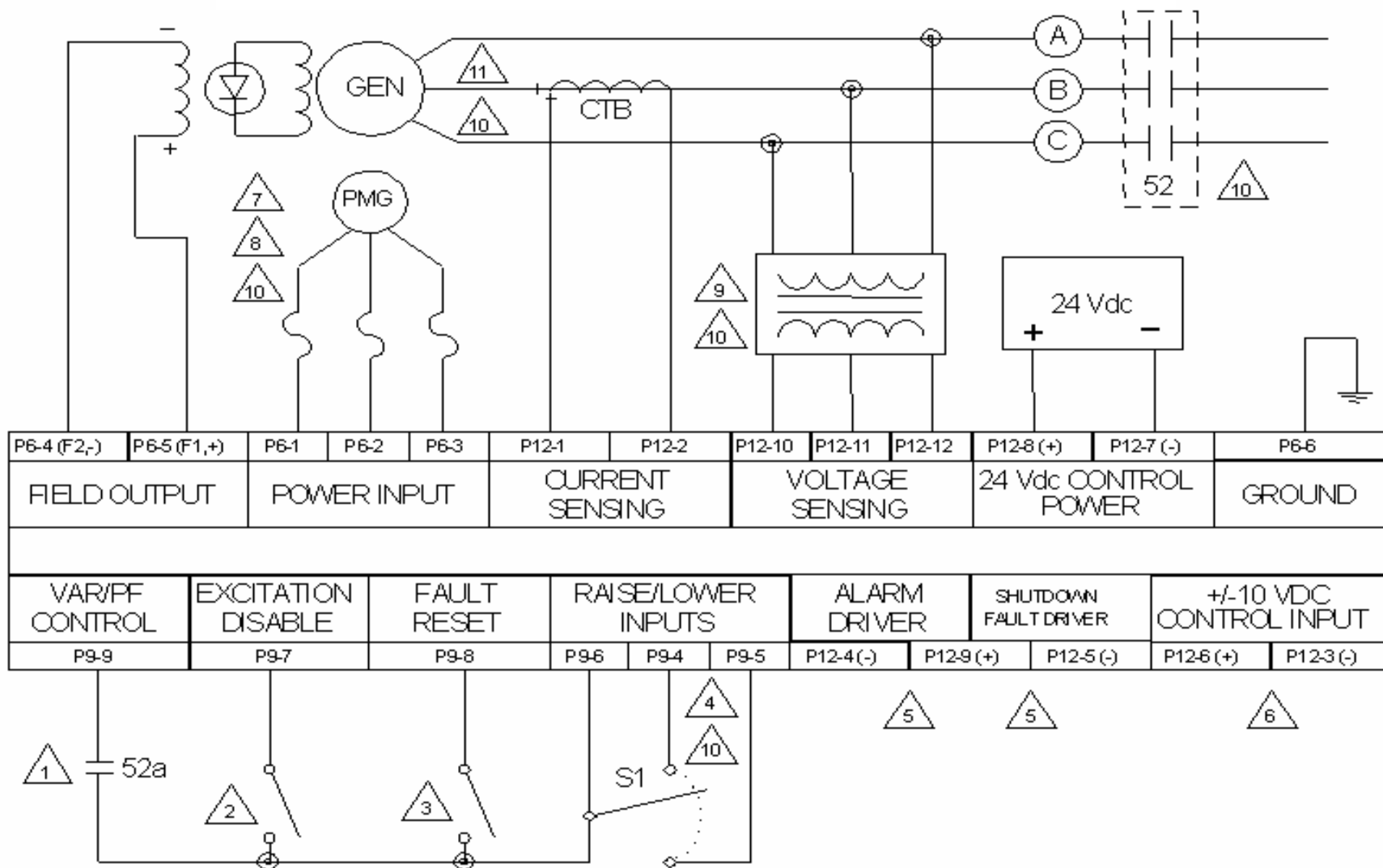

Example PMG Diagram

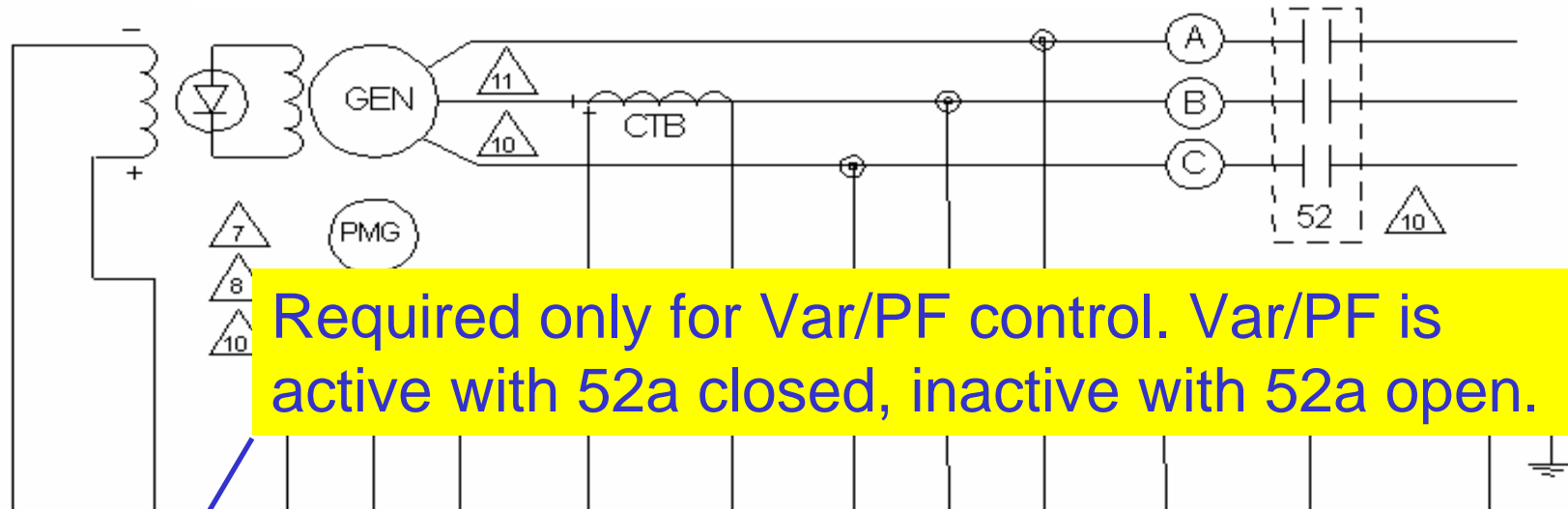

Required only for Var/PF control. Var/PF is active with 52a closed, inactive with 52a open.

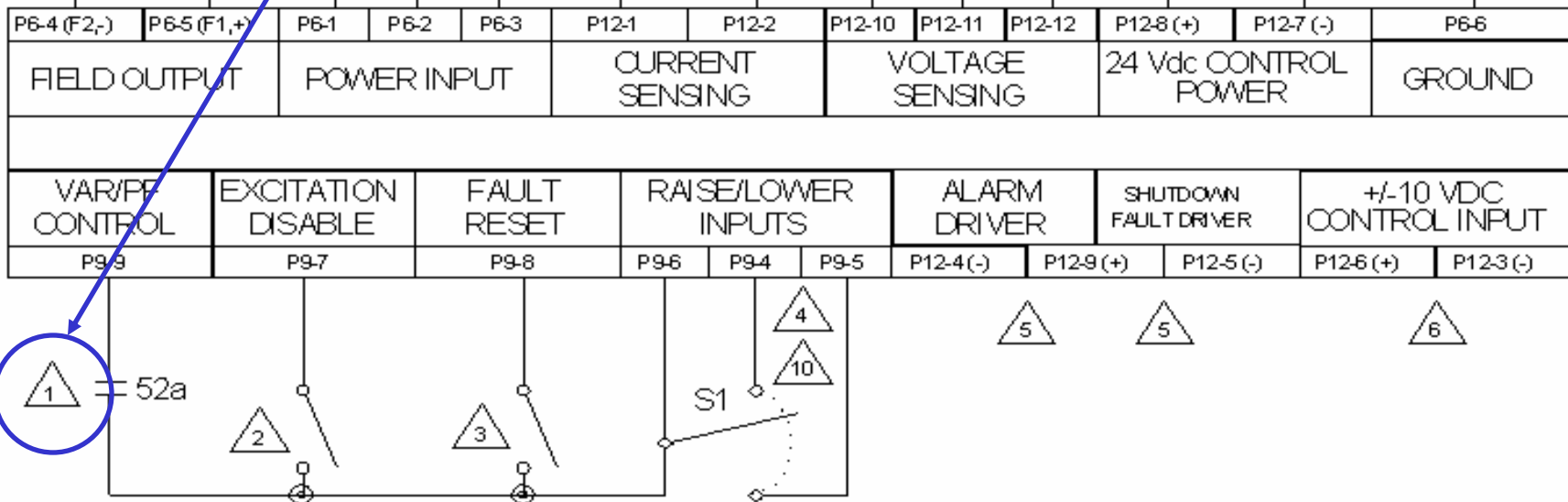

Example PMG Diagram

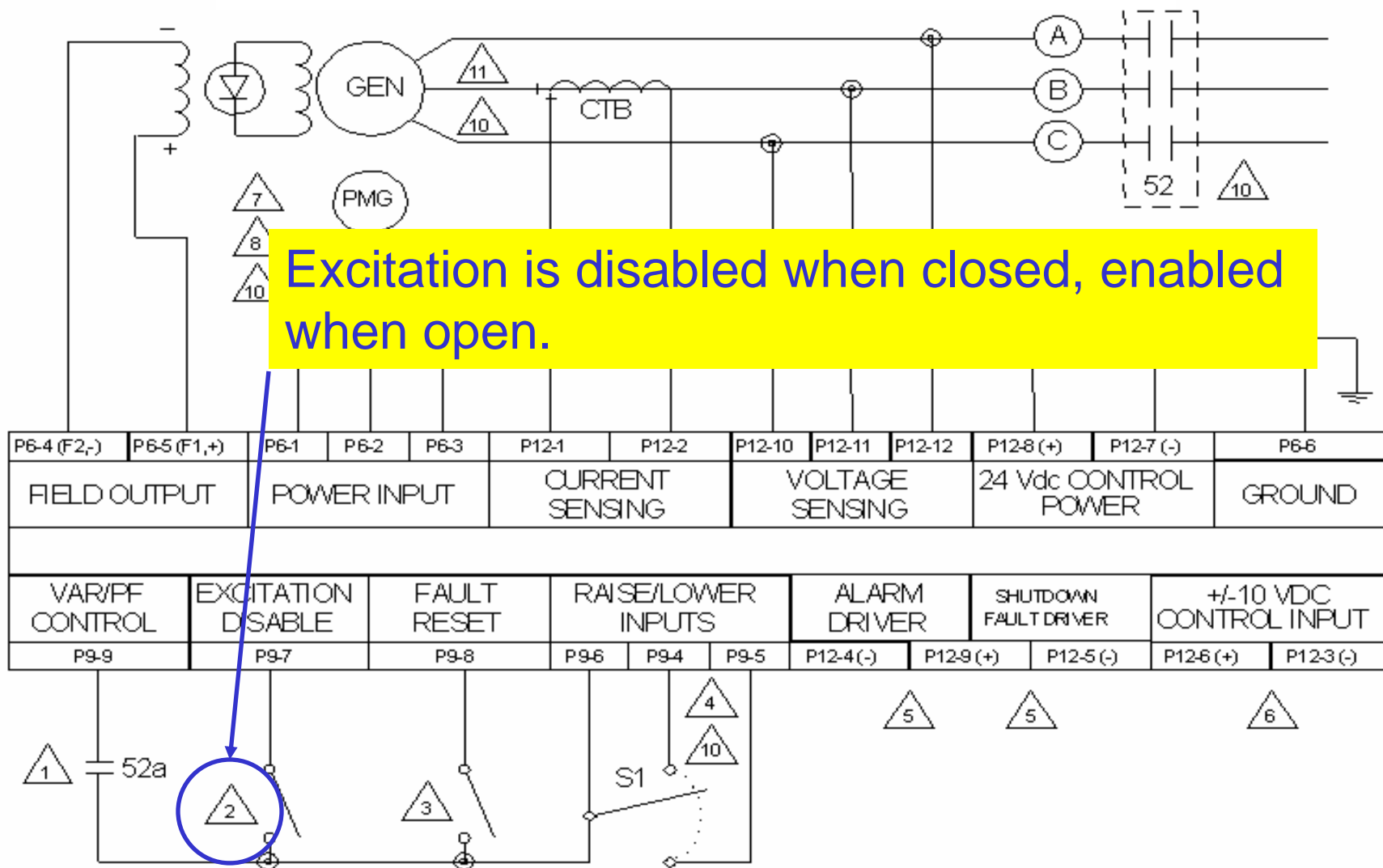

Example PMG Diagram

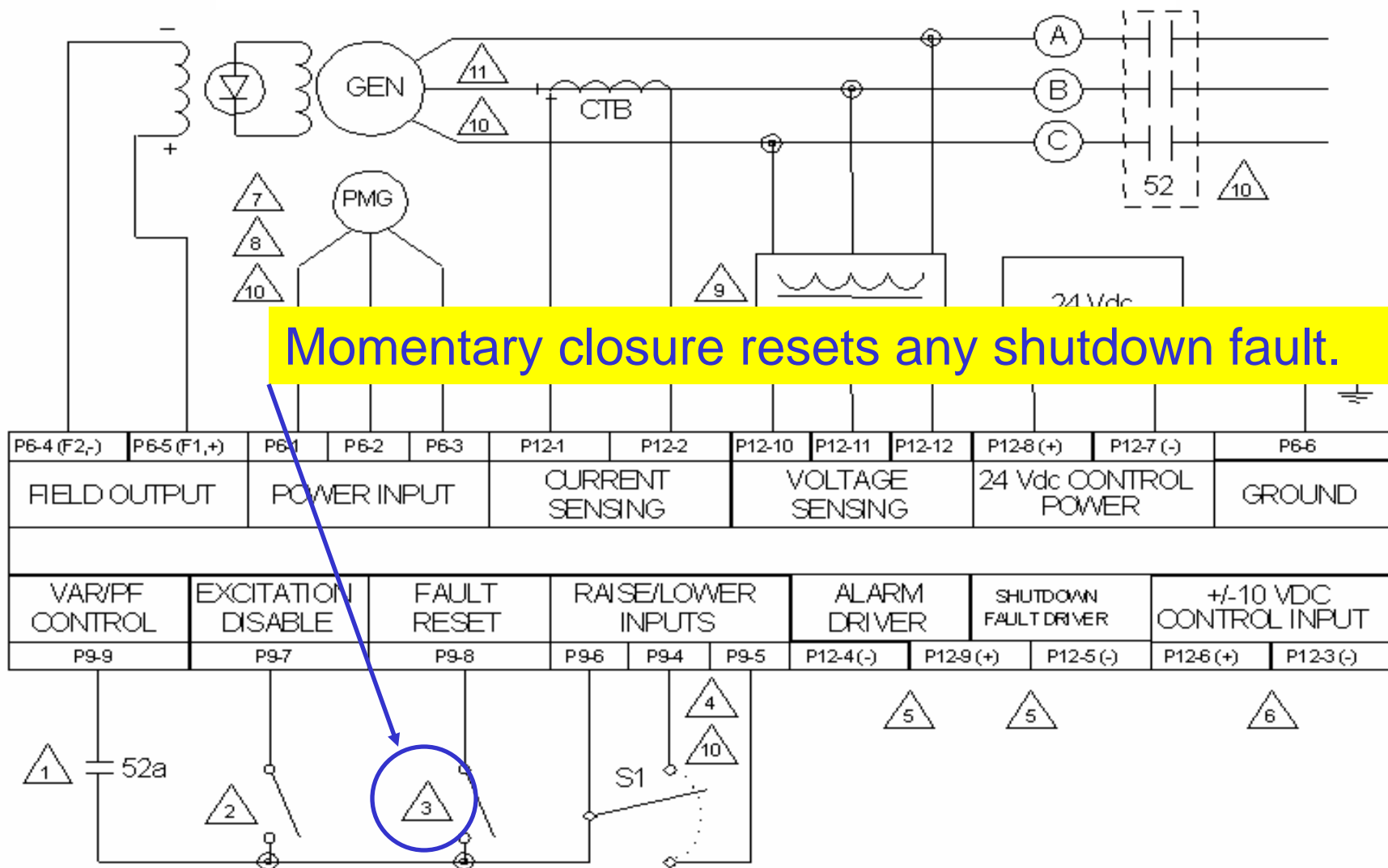

Example PMG Diagram

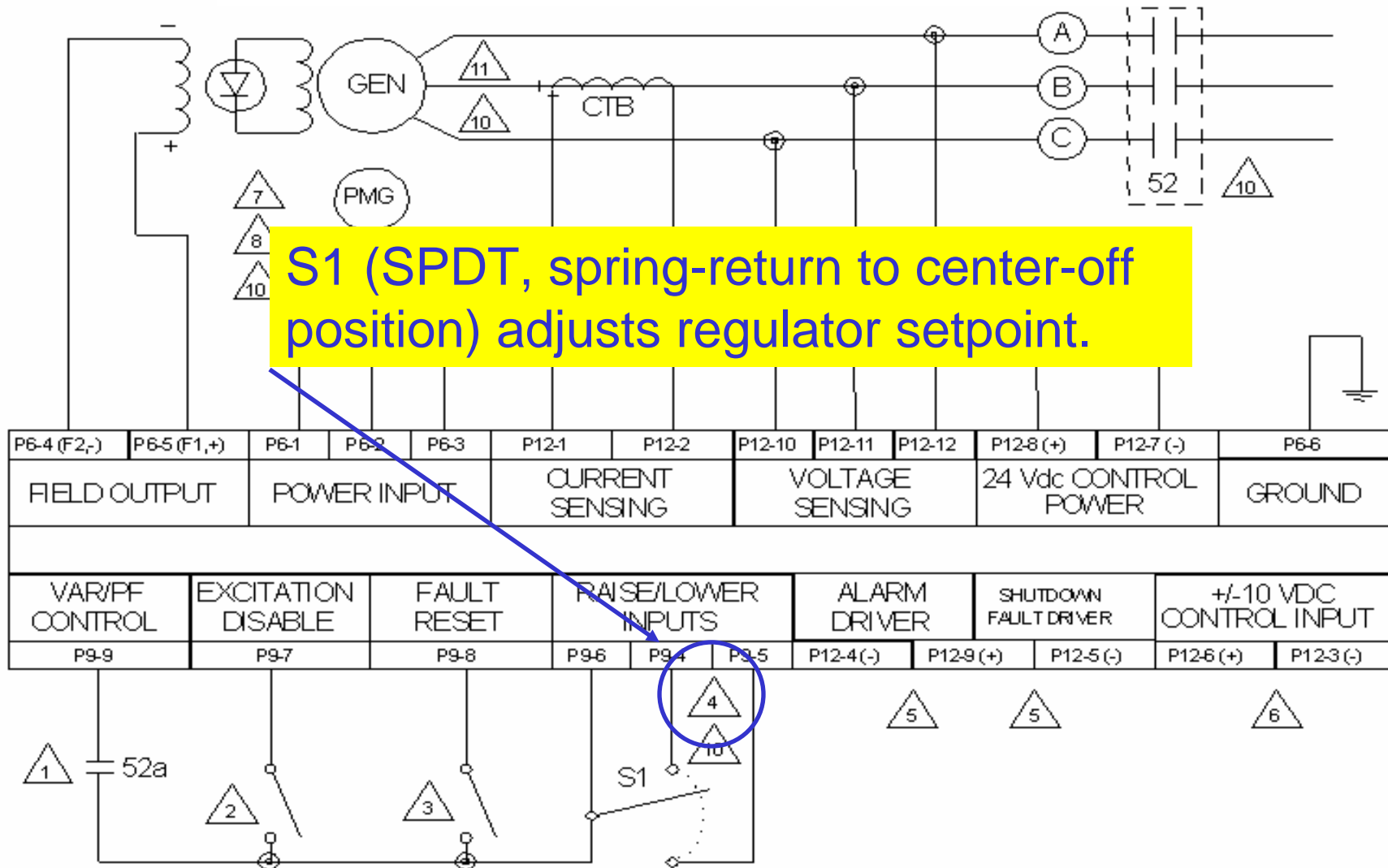

Example PMG Diagram

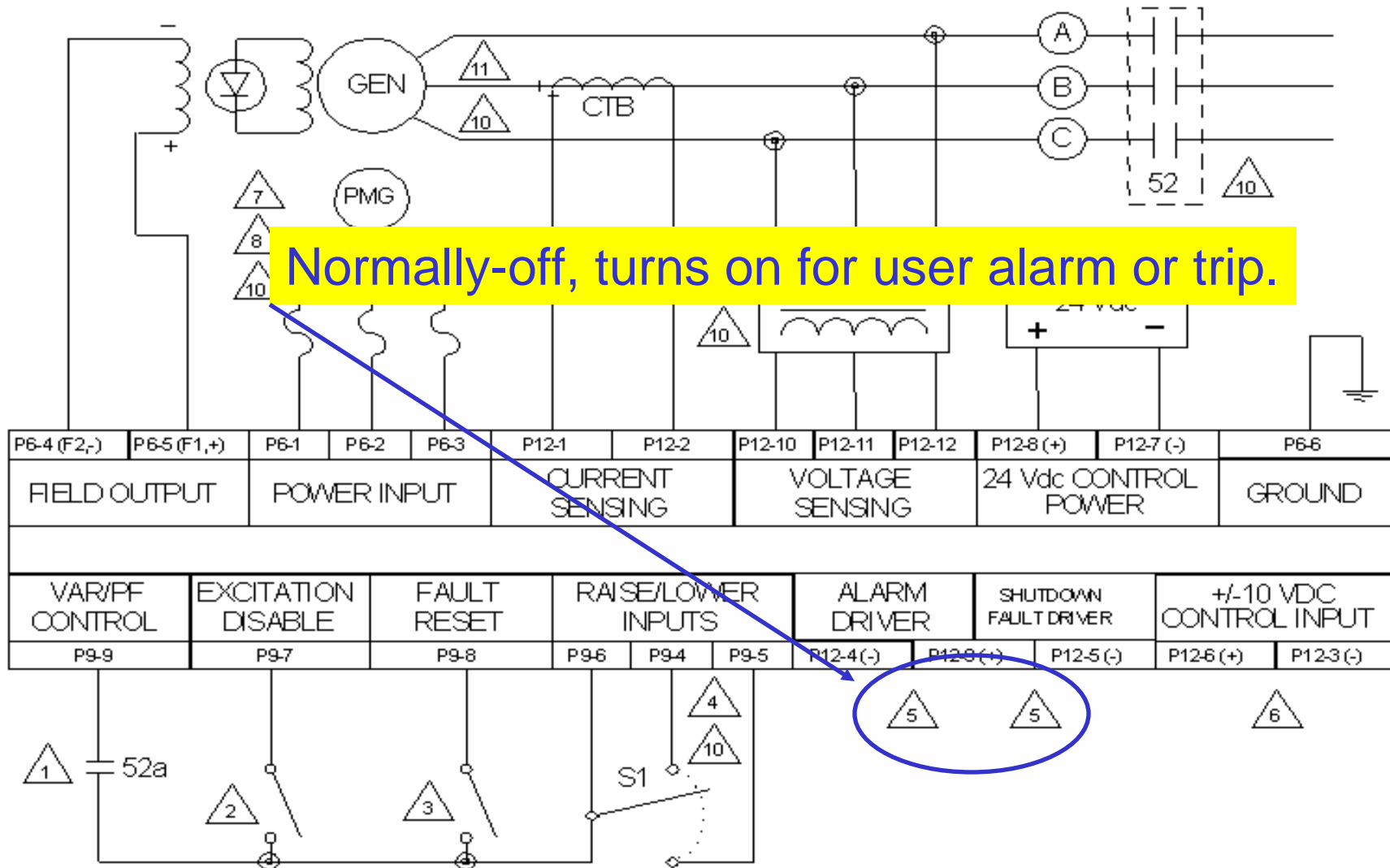

Example PMG Diagram

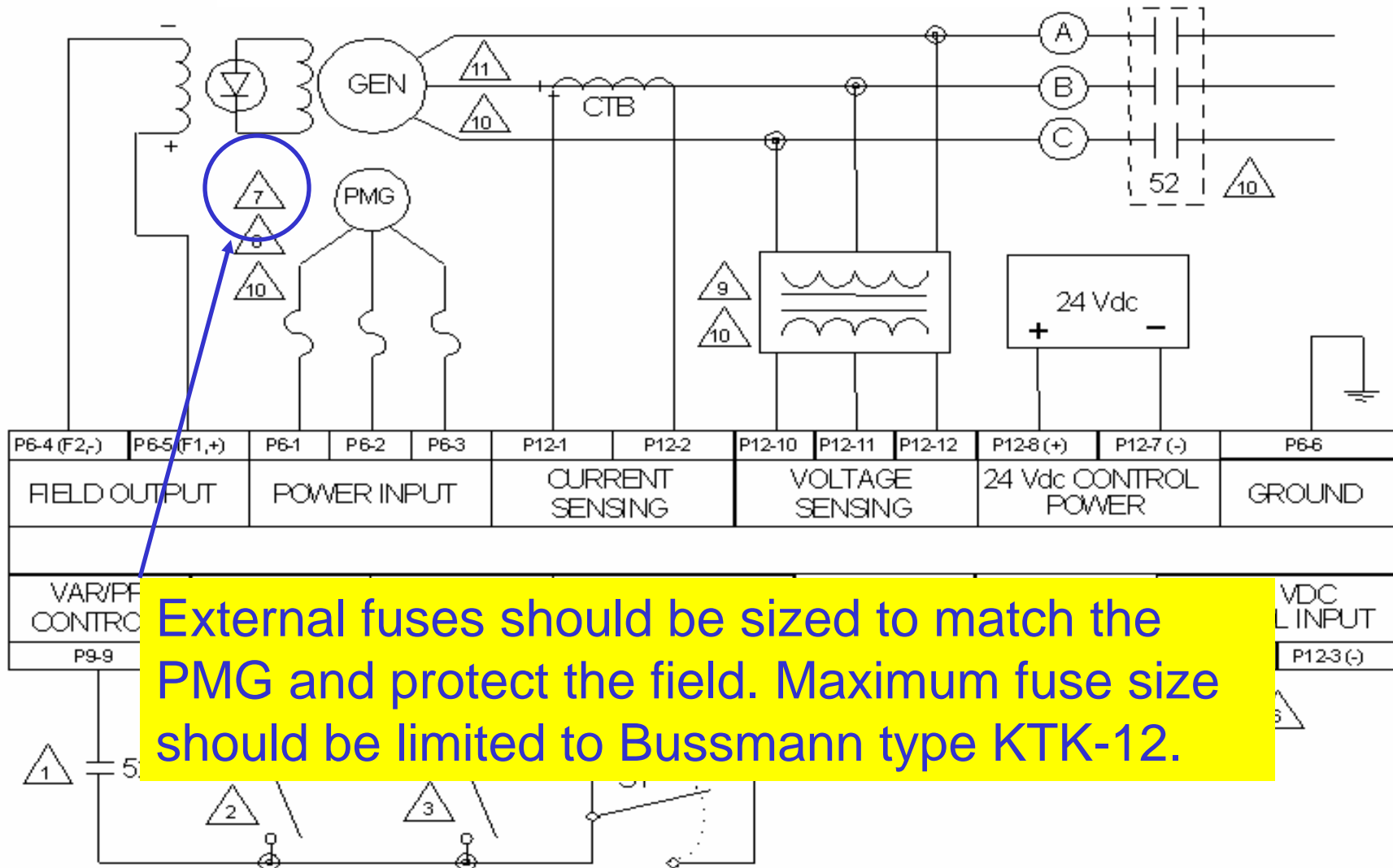

Example PMG Diagram

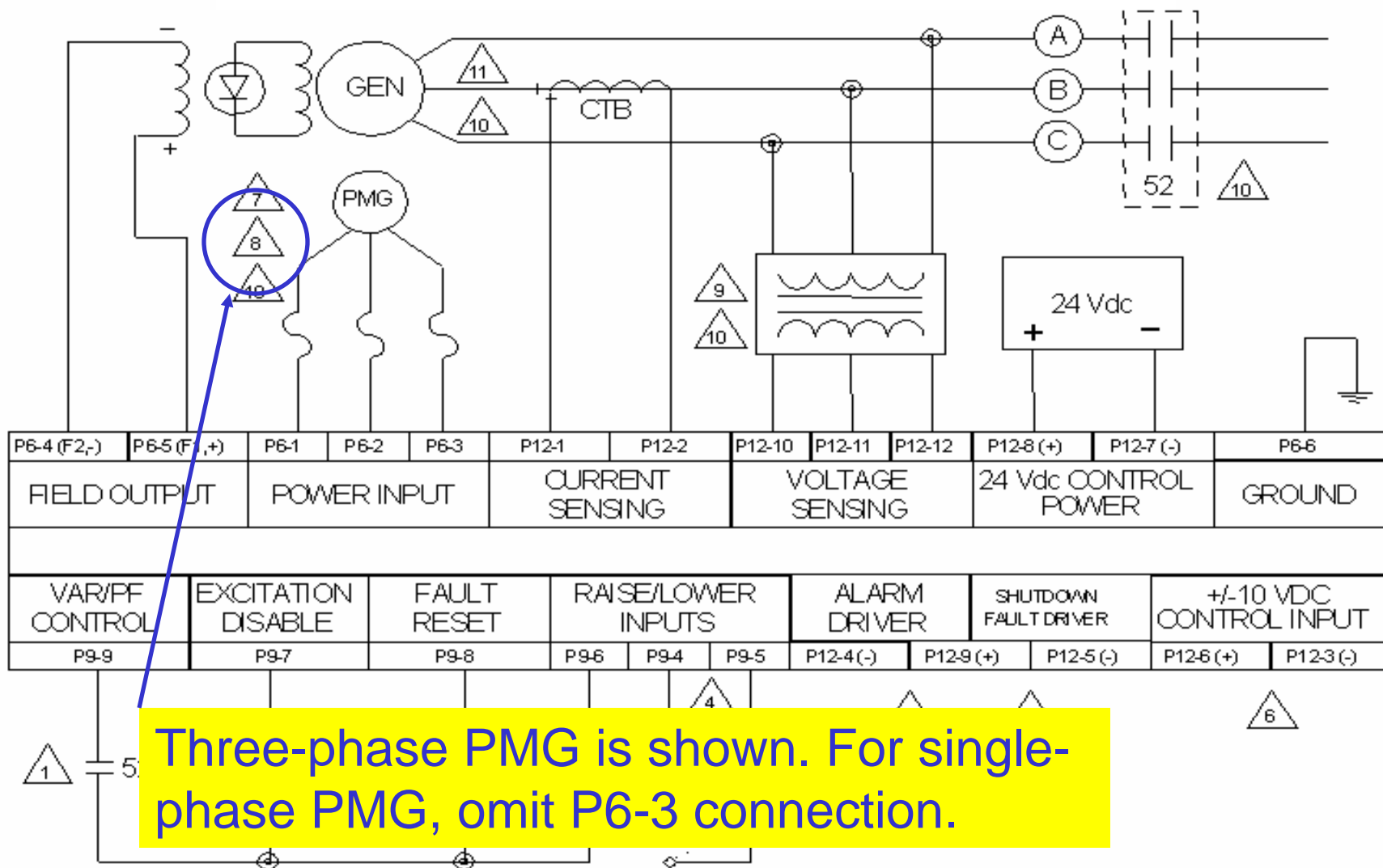

Example PMG Diagram

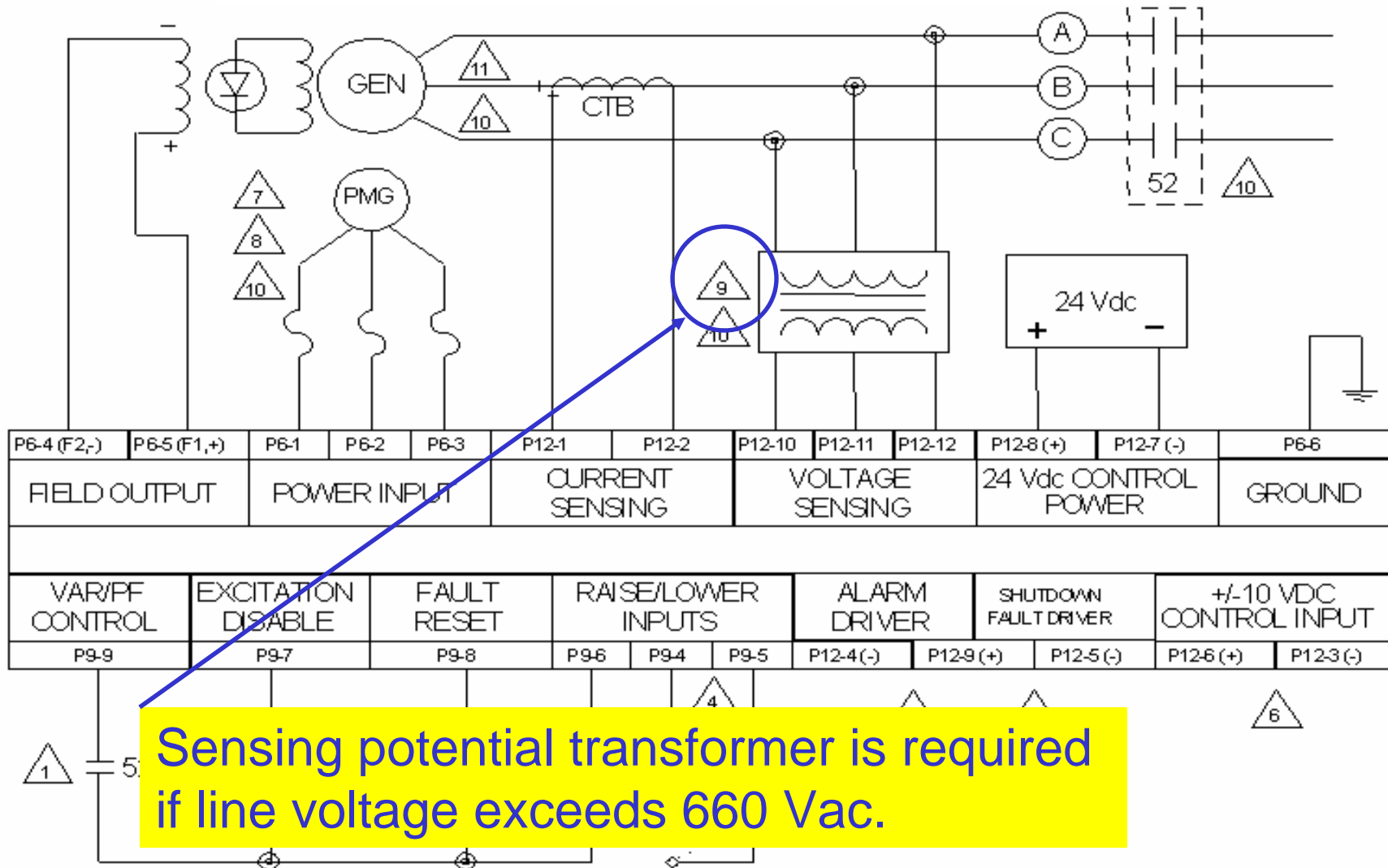

Example PMG Diagram

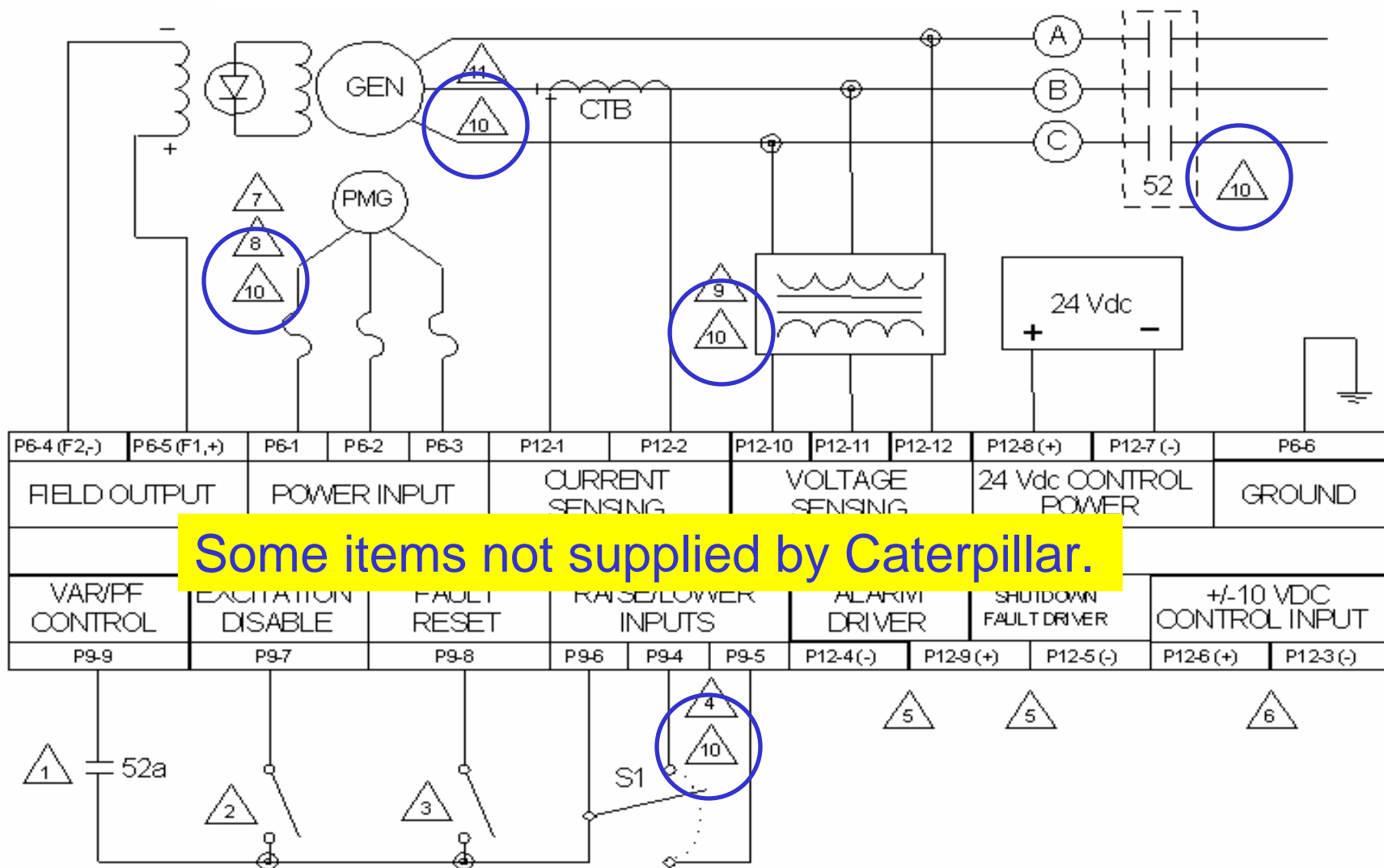

Example PMG Diagram

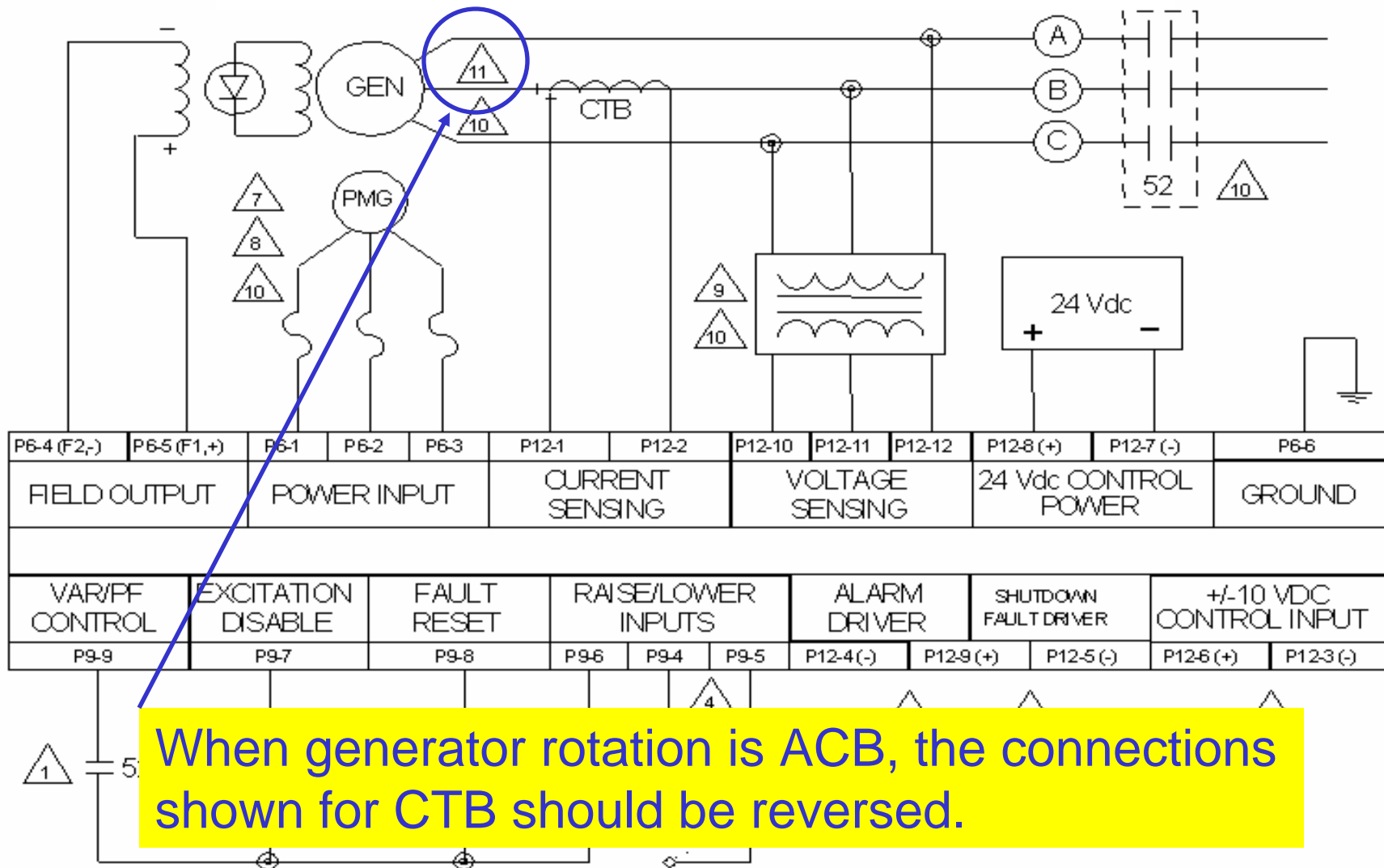

Mounting

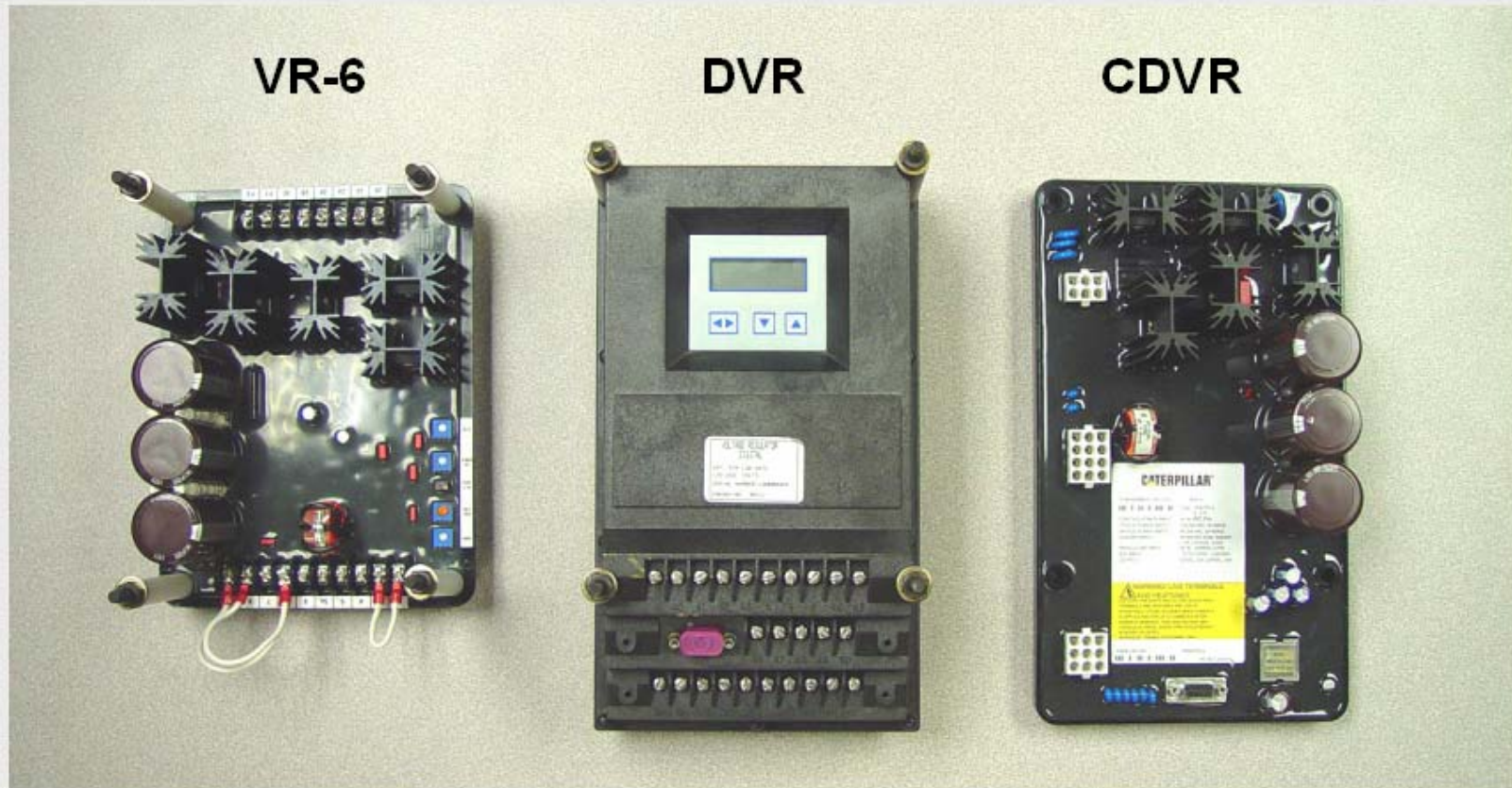

The VR-3 (not shown), VR-6, DVR and new CDVR all have the same bolt pattern and mount in the same location in the generator enclosure.

Reminder – Live Terminals and Heatsinks

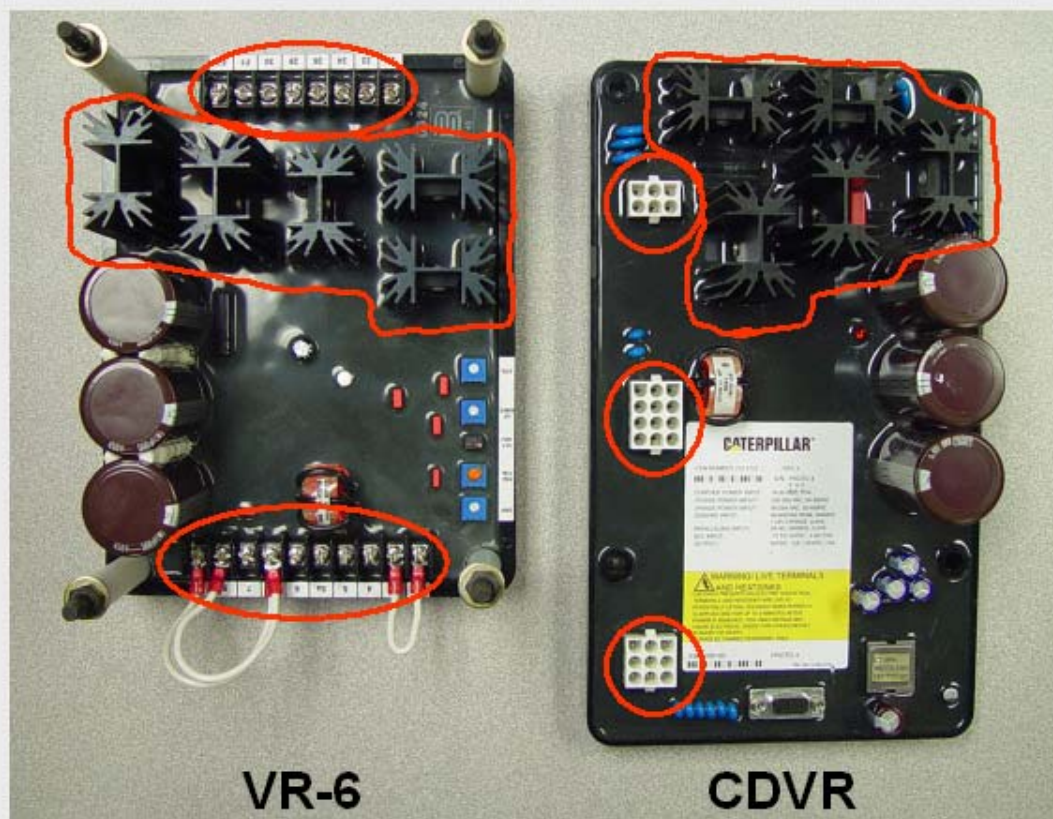

The VR-6 and CDVR both present an electrical shock risk. Terminals and heatsinks are live at potentially lethal voltages when power is applied and for up to 8 minutes after power is removed. This high voltage may cause electrical shock that could result in injury or death. Service by trained personnel only.

Wiring Comparisons to the DVR

- Droop CT wiring
- Fault Alarm and Shutdown Output Driver Logic
- VAR/PF enable, fault reset, and excitation disable inputs
- Remote voltage and VAR/PF adjustment

Wiring Comparisons to the DVR

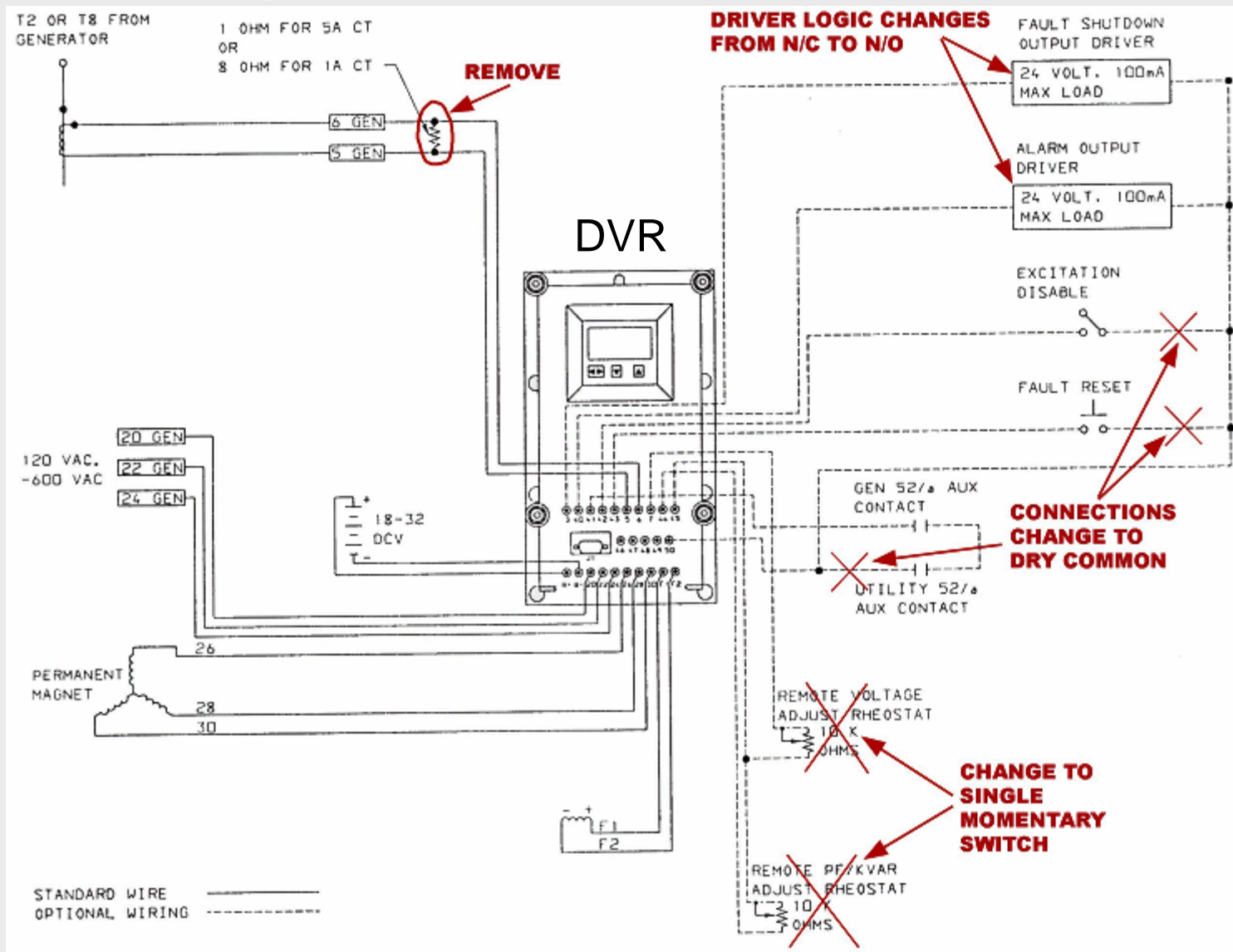

Wiring Comparisons to the DVR

- The DVR uses an 8-ohm resistor with a 1 Amp droop CT or a 1-ohm resistor with a 5 Amp droop CT.
- The CDVR requires a 5 Amp droop CT and no resistor across the CT output.
- Note: CT leads which are not connected to the regulator must be shorted to avoid a potential shock hazard.

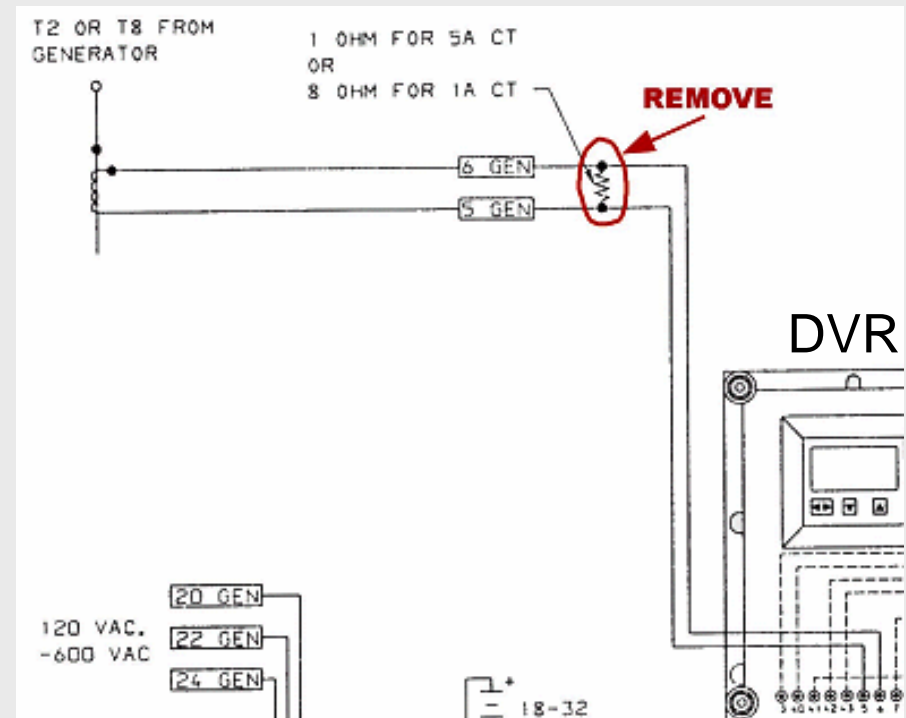

Wiring Comparisons to the DVR

- DVR and CDVR have the output driver logic reversed.
- The DVR low side driver outputs for the fault alarm and shutdown are active high (driver output floats when a fault is active).
- The CDVR low side driver outputs for the alarm and shutdown are active low (driver output pulls low when a fault is active).
- A CDVR output is N/O and would energize to close the output circuit upon an alarm or shutdown.

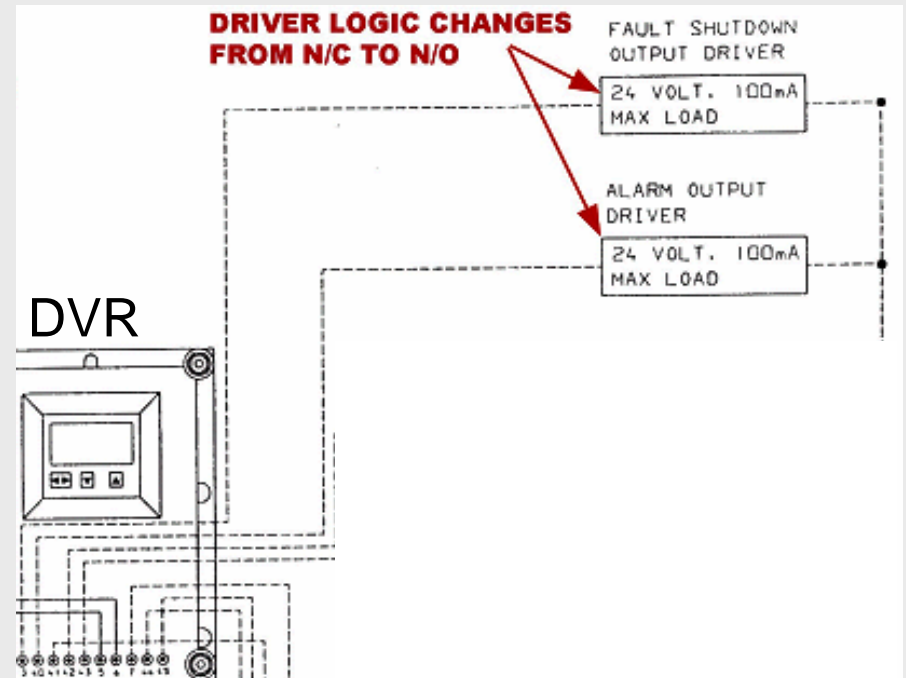

Wiring Comparisons to the DVR

- The DVR VAR/PF enable, fault reset, and excitation disable inputs activate with +24VDC.
- The CDVR VAR/PF enable, fault reset, and excitation disable inputs require a normally open dry contact to enable the function.

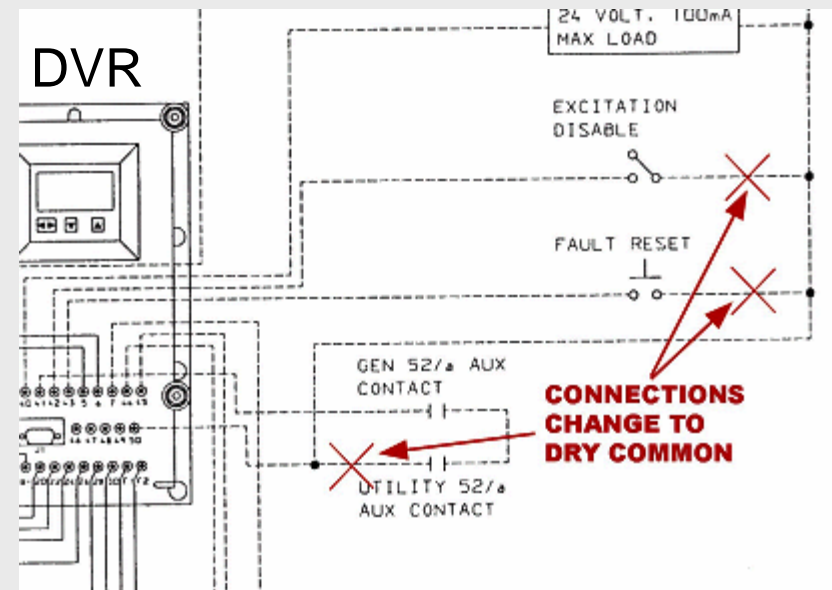

Wiring Comparisons to the DVR

- The DVR utilizes a 10K-ohm potentiometer for remote voltage adjust another for remote VAR/PF adjustments
- The CDVR uses a **single** momentary switch with raise and lower contacts. The switch adjusts voltage in AVR mode and also adjusts VAR or PF if operating in that mode.

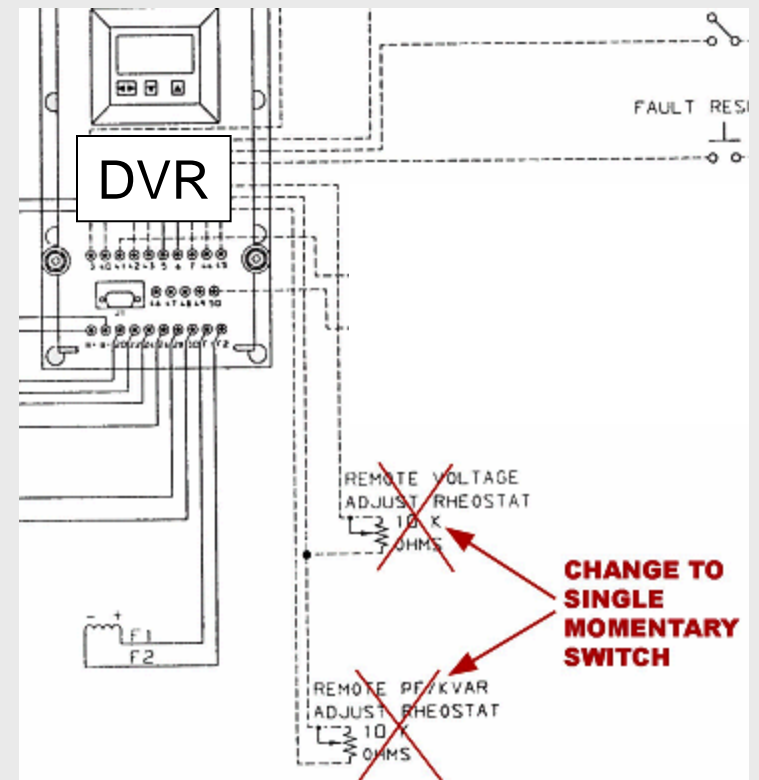

Caterpillar Digital Voltage Regulator (CDVR)

PC Software Installation

Prepared by Service Training

<https://psmktg.cat.com/srvtrng/>

CDVR PC Software Download

- The CDVR PC software and an IBM Compatible Personal Computer or Laptop is required for the service technician to program CDVR set points and parameters and to access status indicators and regulator metering functions.
- This Presentation has detailed steps for downloading the PC Software from SIS (Service Information System), establishing communications and programming the CDVR.

CDVR PC Software Download

- Navigate to SIS at <https://sis.cat.com>

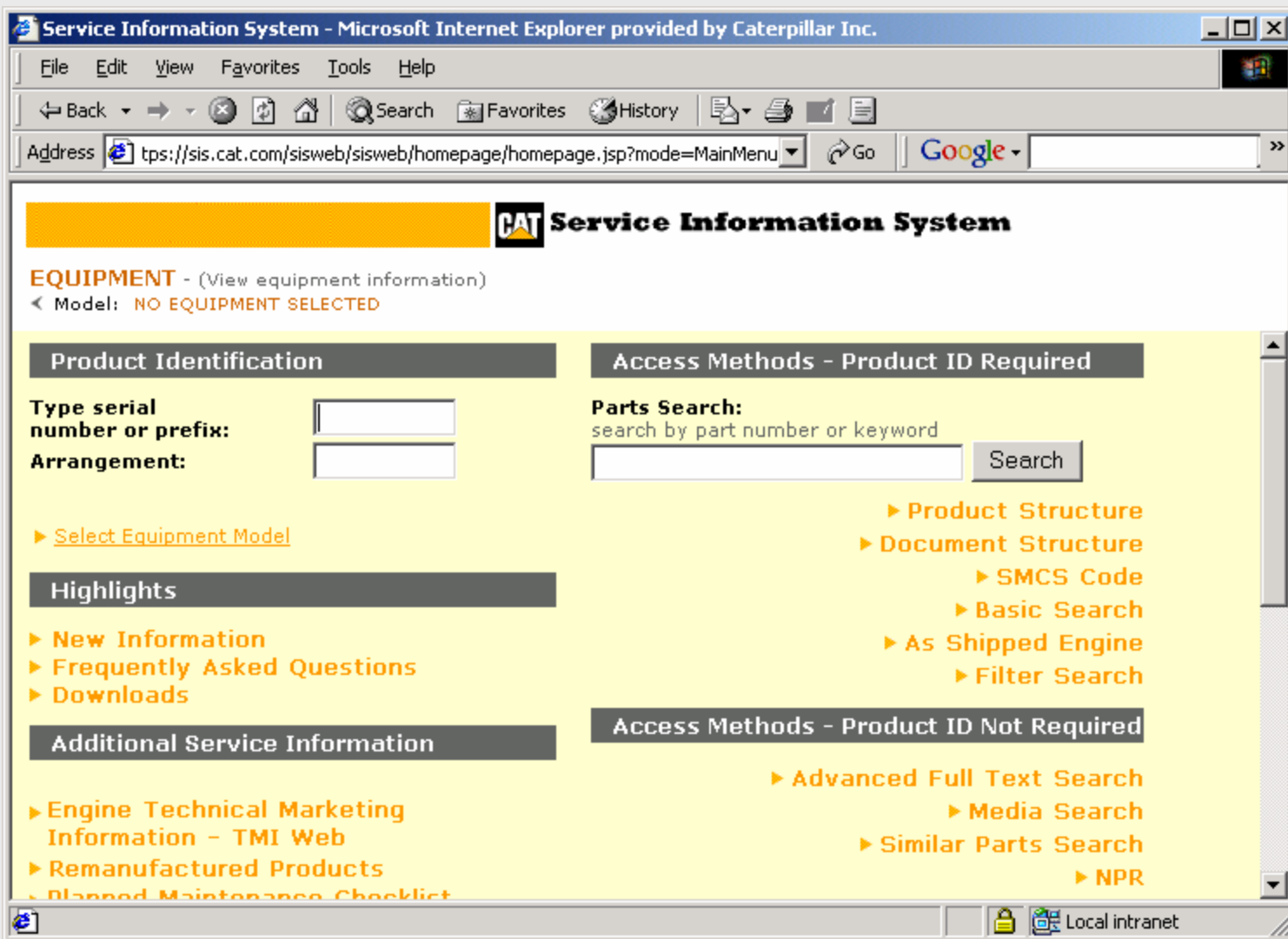

CDVR PC Software Download

- Click on “Downloads”

Service Information System - Microsoft Internet Explorer provided by Caterpillar Inc.

File Edit View Favorites Tools Help

Back Forward Stop Home Search Favorites History Print Mail

Address <tps://sis.cat.com/sisweb/sisweb/homepage/homepage.jsp?mode=MainMenu> Go Google

CAT Service Information System

EQUIPMENT - (View equipment information)
< Model: NO EQUIPMENT SELECTED

Product Identification

Type serial number or prefix:
Arrangement:

[Select Equipment Model](#)

Highlights

- ▶ New Information
- ▶ Frequently Asked Questions
- ▶ Downloads

Additional Service Information

- ▶ Engine Technical Marketing Information - TMI Web
- ▶ Remanufactured Products
- ▶ Planned Maintenance Checklist

Access Methods - Product ID Required

Parts Search:
search by part number or keyword Search

- ▶ Product Structure
- ▶ Document Structure
 - ▶ SMCS Code
 - ▶ Basic Search
 - ▶ As Shipped Engine
 - ▶ Filter Search

Access Methods - Product ID Not Required

- ▶ Advanced Full Text Search
 - ▶ Media Search
- ▶ Similar Parts Search
 - ▶ NPR

Local intranet

CDVR PC Software Download

- Click on “CDVR PC Software.exe”

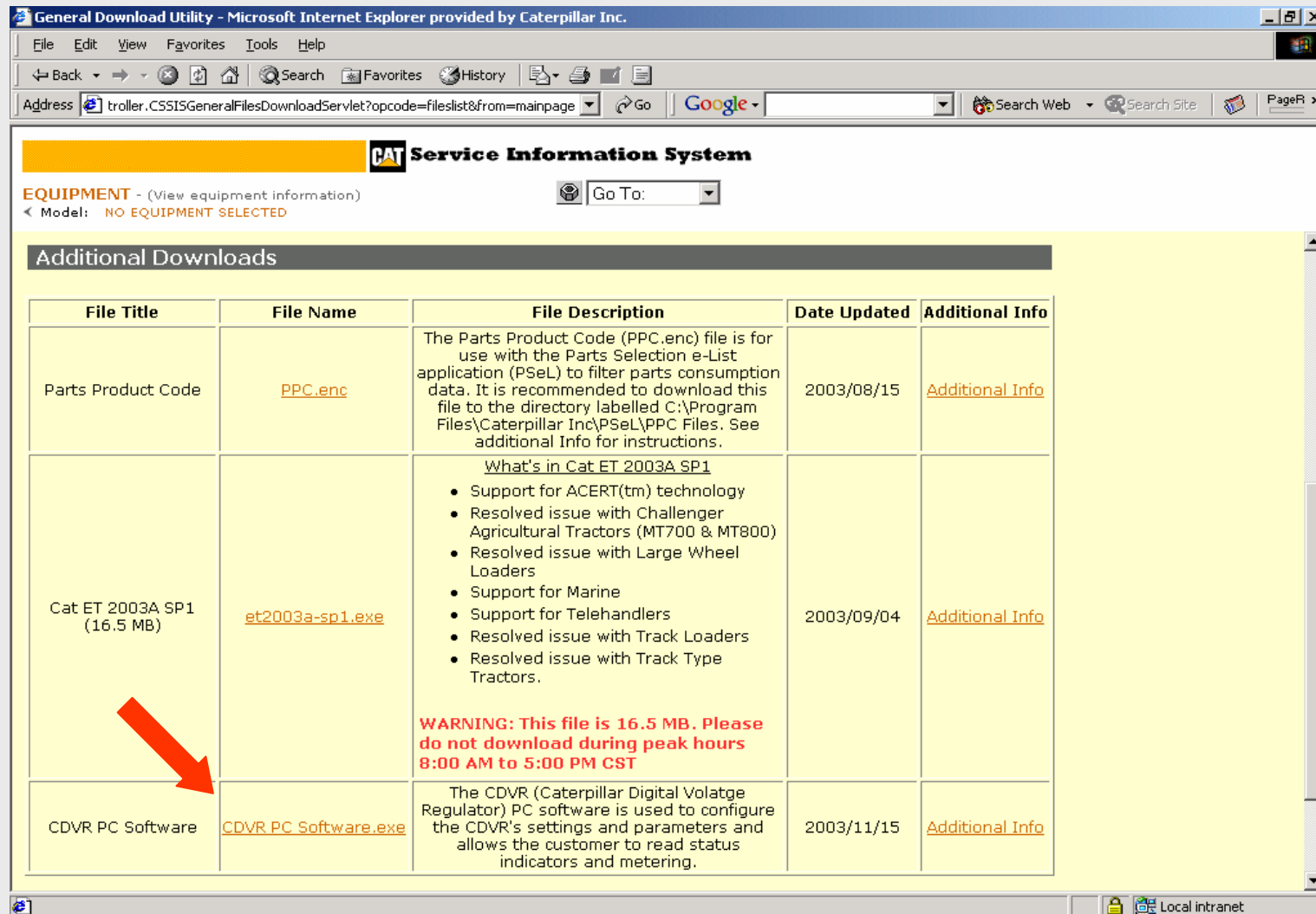

General Download Utility - Microsoft Internet Explorer provided by Caterpillar Inc.

File Edit View Favorites Tools Help

Address [troller.CSSISGeneralFilesDownloadServlet?topcode=fileslist&from=mainpage](#) Go Search Web Search Site PageR >>

CAT Service Information System

EQUIPMENT - (View equipment information)

< Model: NO EQUIPMENT SELECTED

Additional Downloads

File Title	File Name	File Description	Date Updated	Additional Info
Parts Product Code	PPC.enc	The Parts Product Code (PPC.enc) file is for use with the Parts Selection e-List application (PSeL) to filter parts consumption data. It is recommended to download this file to the directory labelled C:\Program Files\Caterpillar Inc\PSeL\PPC Files. See additional Info for instructions.	2003/08/15	Additional Info
Cat ET 2003A SP1 (16.5 MB)	et2003a-sp1.exe	<u>What's in Cat ET 2003A SP1</u> <ul style="list-style-type: none">• Support for ACERT(tm) technology• Resolved issue with Challenger Agricultural Tractors (MT700 & MT800)• Resolved issue with Large Wheel Loaders• Support for Marine• Support for Telehandlers• Resolved issue with Track Loaders• Resolved issue with Track Type Tractors. WARNING: This file is 16.5 MB. Please do not download during peak hours 8:00 AM to 5:00 PM CST	2003/09/04	Additional Info
CDVR PC Software	CDVR_PC_Software.exe	The CDVR (Caterpillar Digital Voltage Regulator) PC software is used to configure the CDVR's settings and parameters and allows the customer to read status indicators and metering.	2003/11/15	Additional Info

Local intranet

CDVR PC Software Download

- Verify “Save this file to disk” is selected as shown and then click the “OK” button

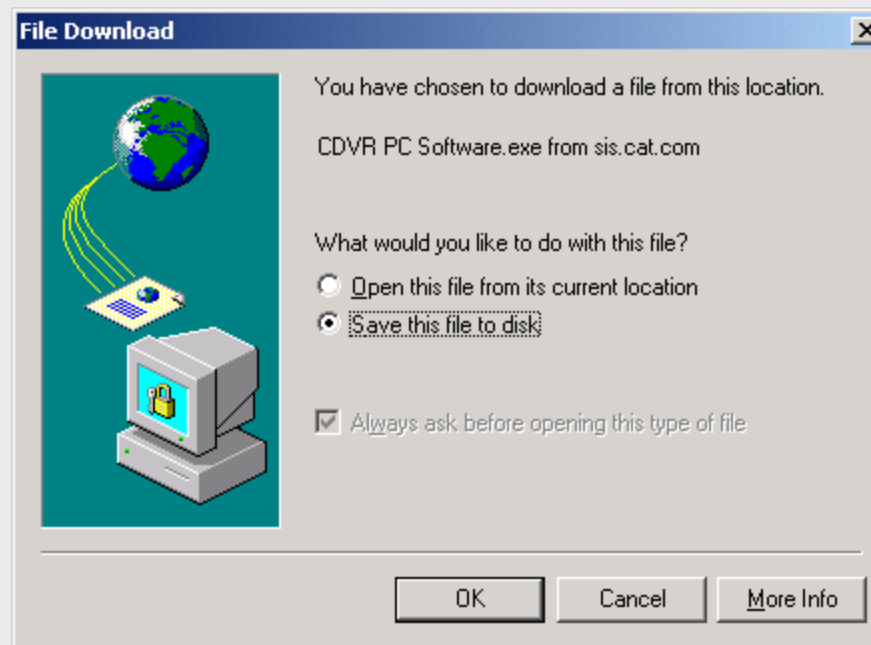

CDVR PC Software Download

- Select where to save the file. The example shows the file being saved as “CDVR PC Software” to the computer Desktop.

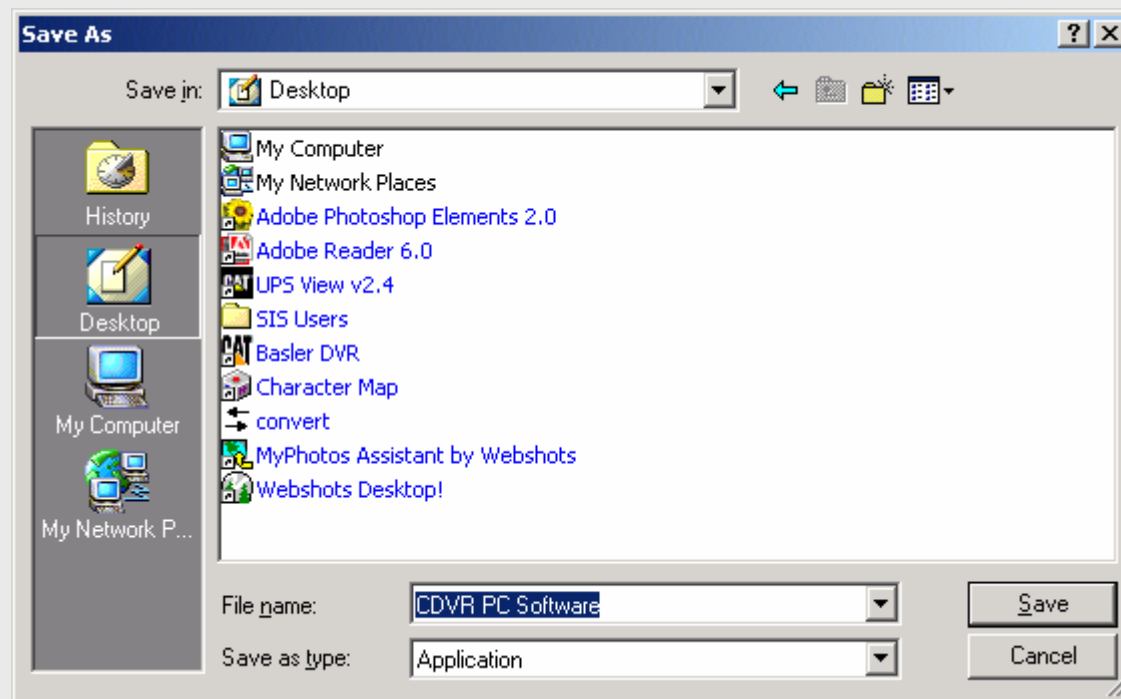

CDVR PC Software Download

- The “CDVR PC Software” file will download and a Download Complete box will appear when the download is complete. Click “Close”.
- This file is 6.17MB in size and may take longer with slower network or modem connections.
- This completes the software download.

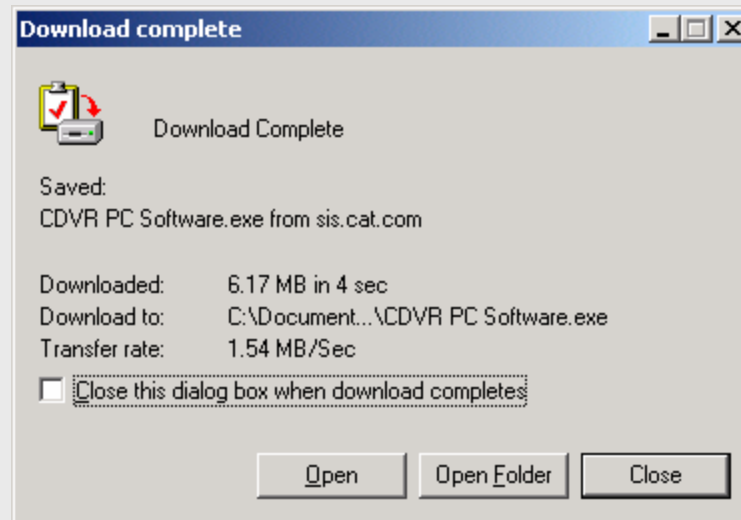

CDVR PC Software Installation

- Run the file by double-clicking on the file “CDVR PC Software” 
- If the file has not been saved to the desktop, navigate to the folder where it was saved and open the CDVR PC Software program file as shown below.

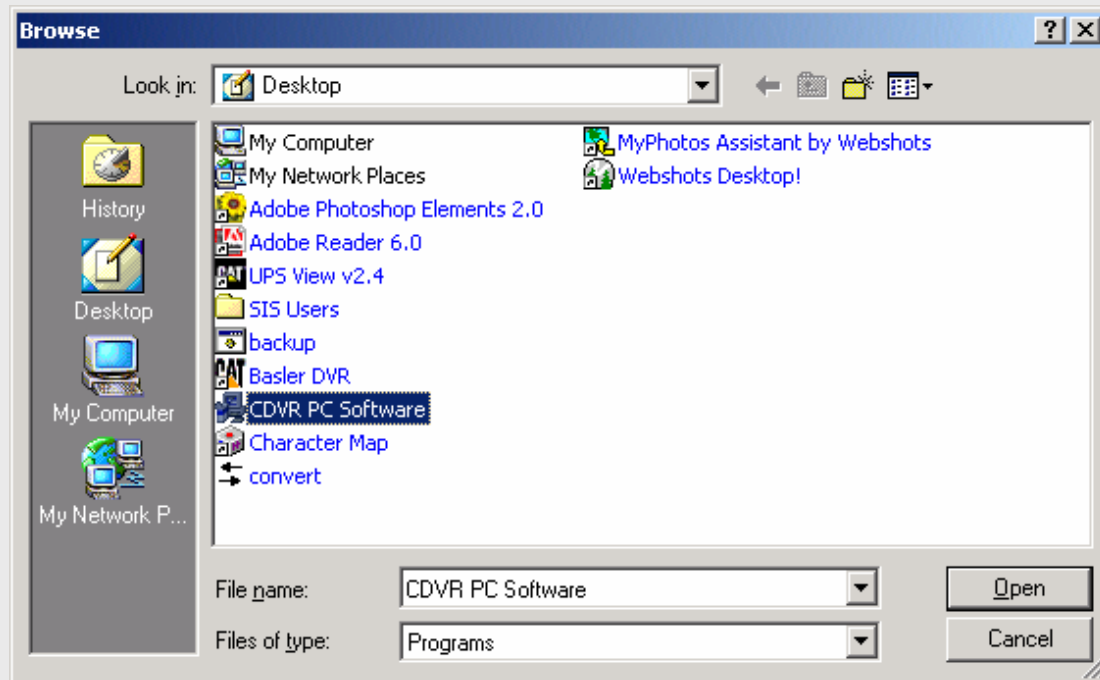

CDVR PC Software Installation

- Follow the installation instructions and click “Next” when ready.

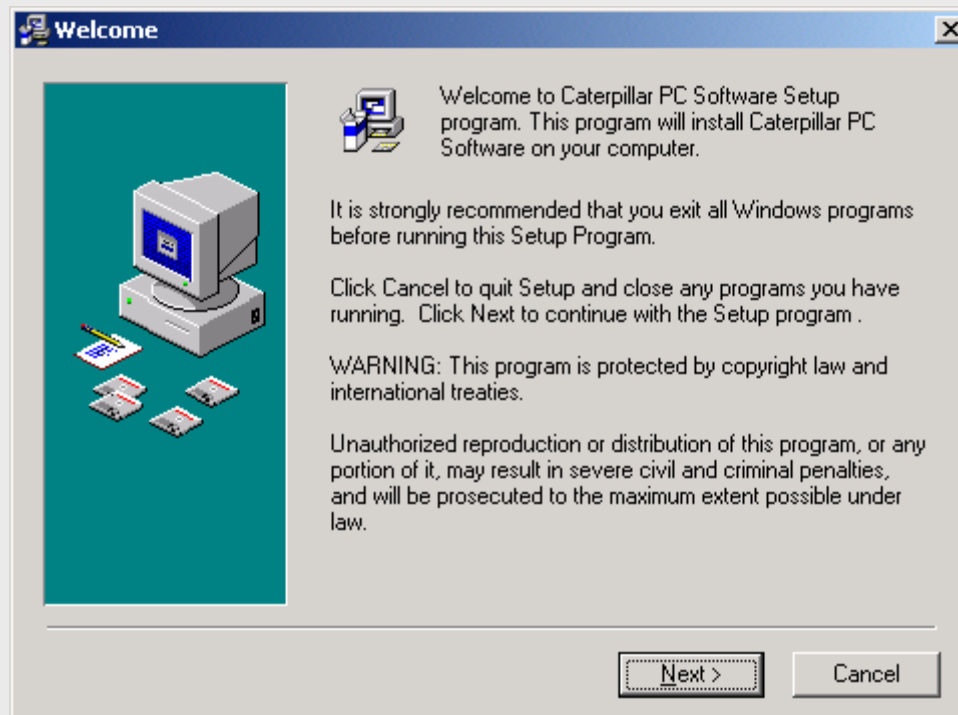

CDVR PC Software Installation

- Verify the folder location and click “Next”.

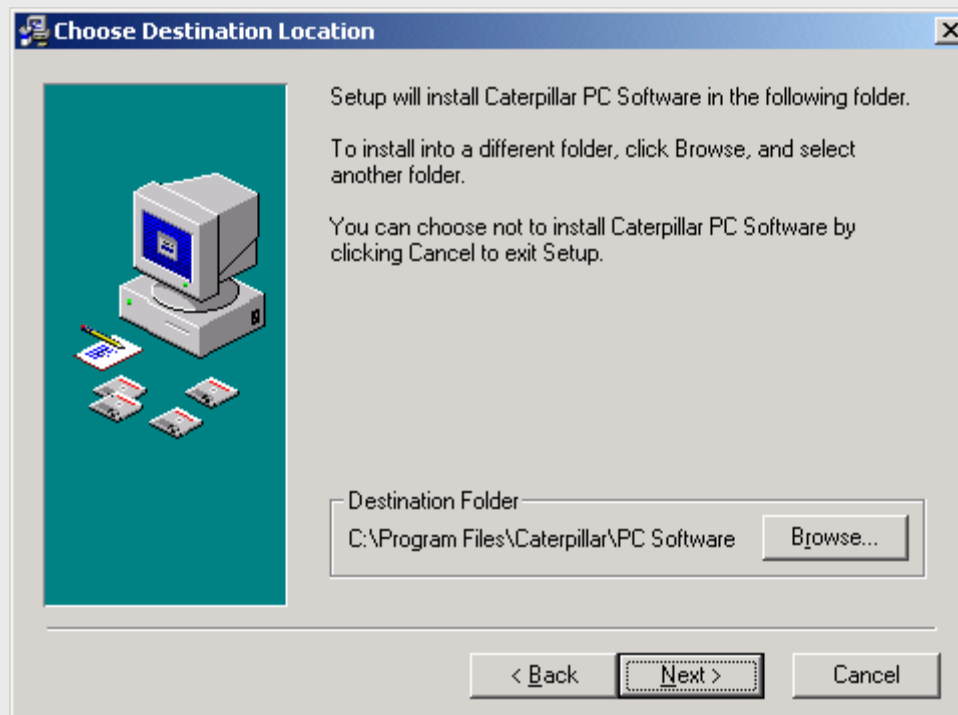

CDVR PC Software Installation

- Click “Next”...

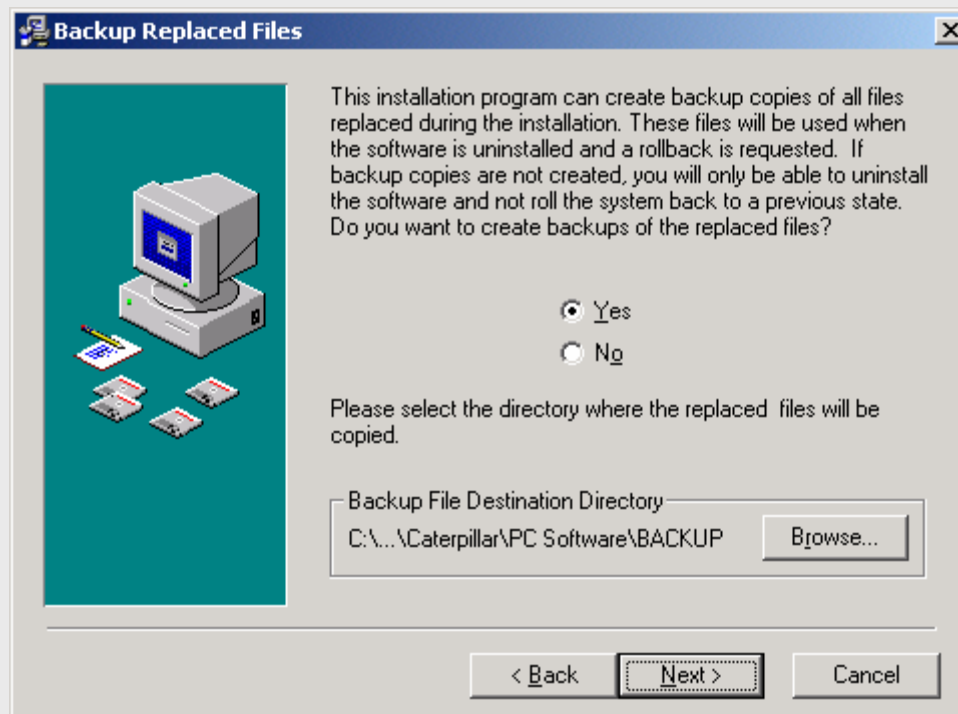

CDVR PC Software Installation

- Click “Next”...

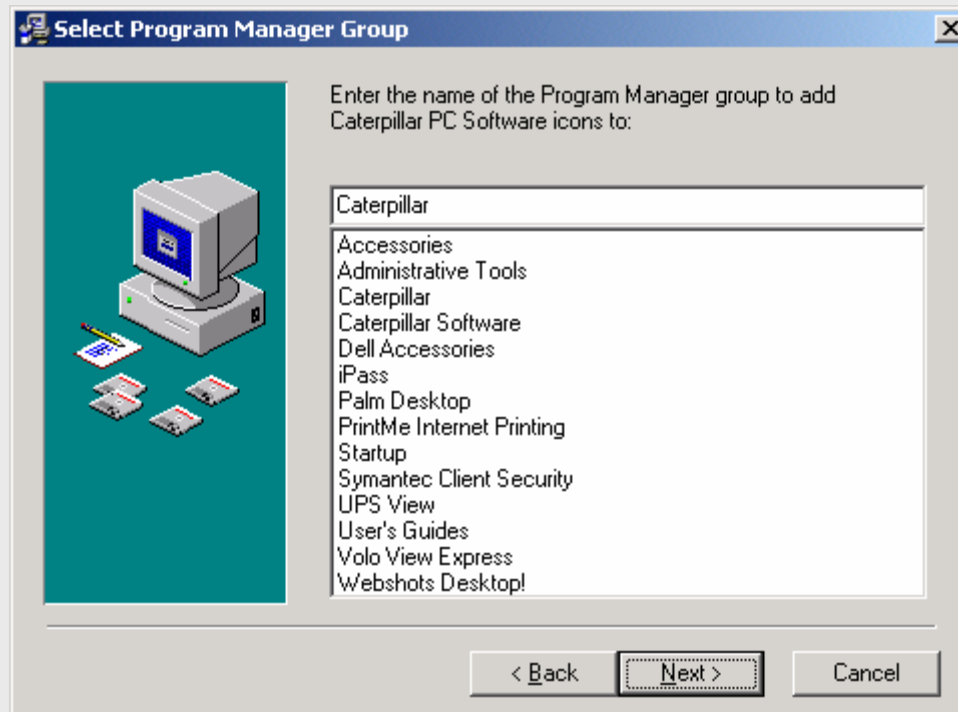

CDVR PC Software Installation

- Click “Next”

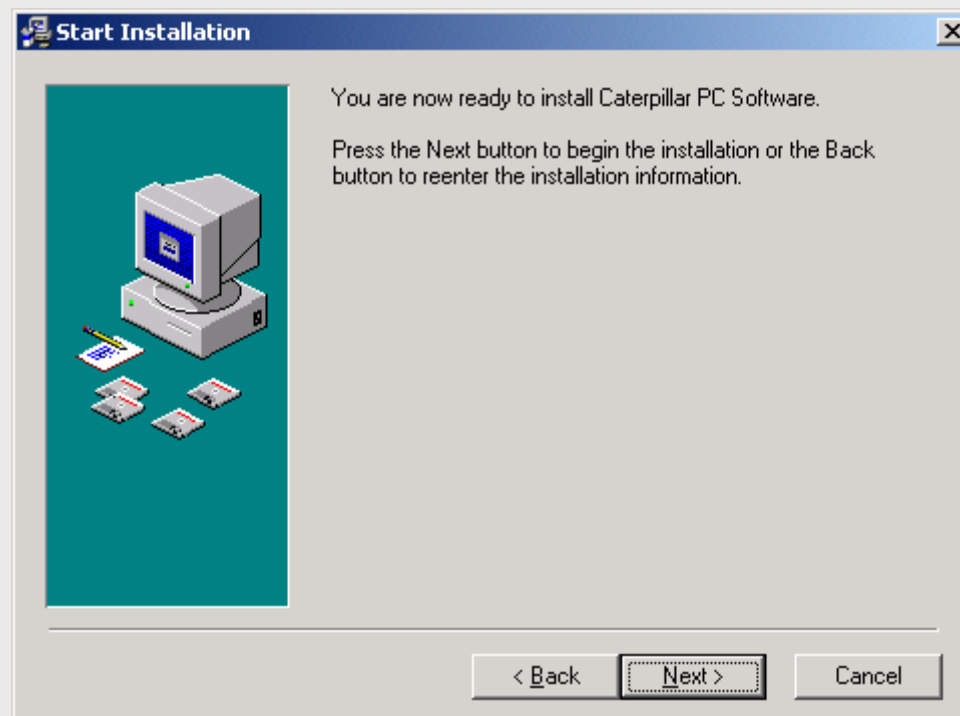

CDVR PC Software Installation

- A window will appear with the bars showing the installation...

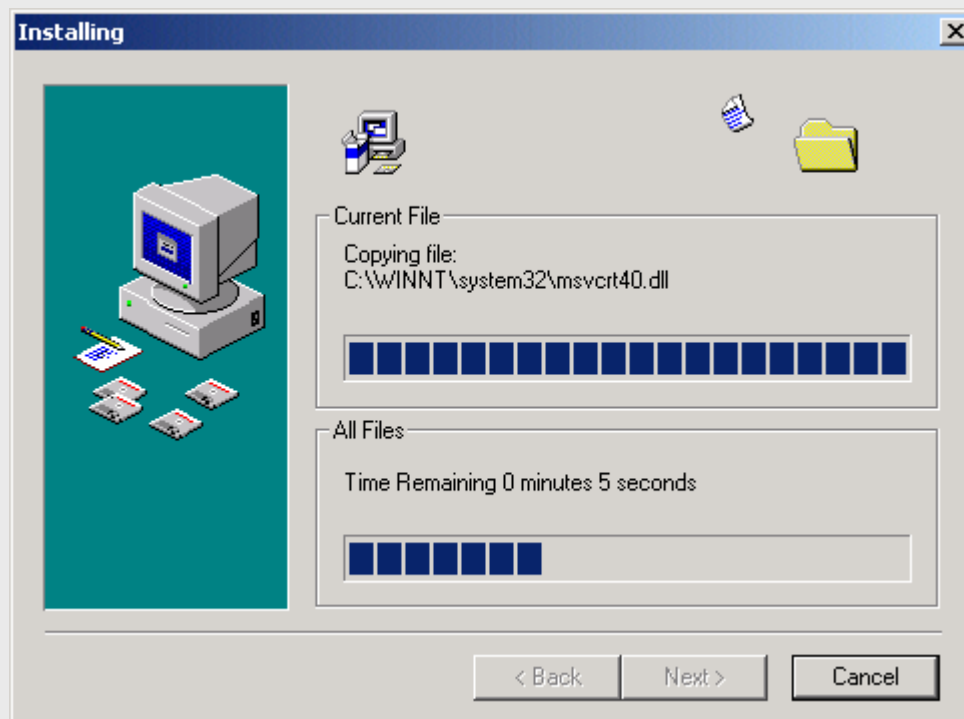

CDVR PC Software Installation

- When the installation is complete click “Finish”
- This completes the software Installation

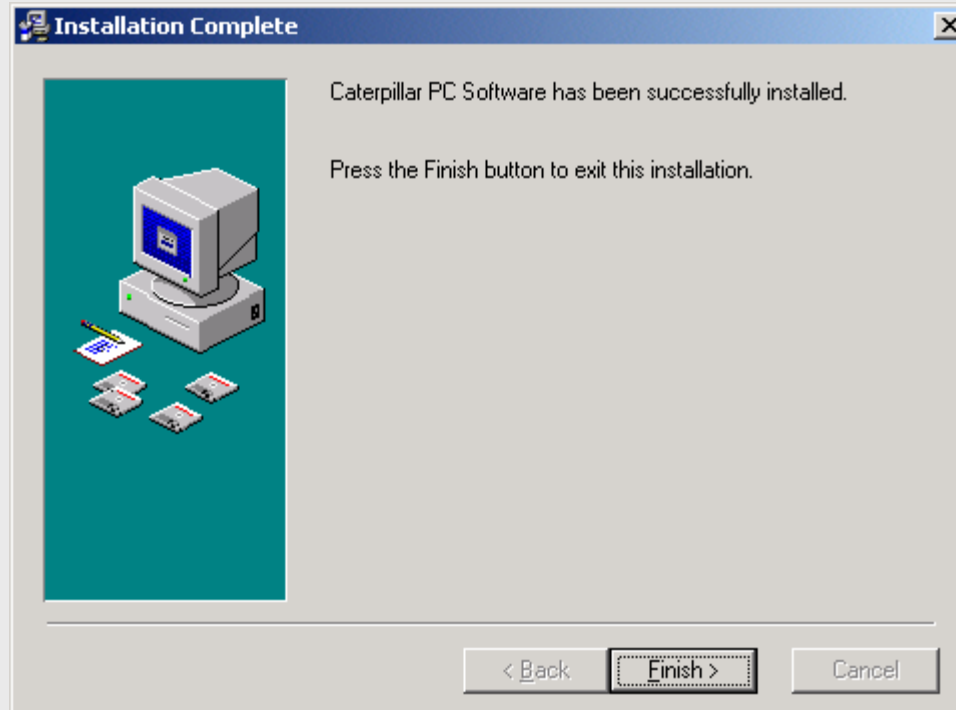

CDVR PC Software

The screenshot shows a Windows 2000 Professional desktop. The Start menu is open, and the user has navigated through the following path: Start > Programs > Caterpillar Software > CAT PC Software. The background window is titled 'Product Identification' and contains a 'Type serial number or prefix:' field, an 'Arrangement:' field, and a 'Search' button. The taskbar at the bottom shows the Start button, several application icons, and the system tray with the time 3:15 PM.

Product Identification

Type serial number or prefix:

Arrangement:

Palm Desktop

Notes R5

NetMeeting

Sametime Connect

Programs

Favorites

Documents

Settings

Search

Help

Run...

Log Off rothbt...

Eject PC

Shut Down...

Accessories

Caterpillar Software

Dell Accessories

Palm Desktop

Startup

User's Guides

Internet Explorer

Lotus Notes 4.6.4

Windows Media Player

Webshots Desktop!

iPass

IBM Mainframe

iPassConnect Corporate

Acrobat Reader 5.0

Nortel Extranet Access Client

SnagIt 5

GTR

Create CD

Outlook Express

Cat ET

QuickSize

PrintMe Internet Printing

Volo View Express

Adobe Reader 6.0

Microsoft Project

Adobe Photoshop Elements 2.0

Symantec Client Security

Caterpillar

UPS View

Methods - Product ID Required

Caterpillar Image Base

Electric Power QuickSize

CAT PC Software - Uninstall

CAT PC Software

Product Structure

Document Structure

SMCS Code

Basic Search

Search

To start the CDVR PC software follow these four steps.

1. Click the Start button
2. Click Programs
3. Click Caterpillar Software
4. Click Cat PC Software

Windows 2000 Professional

Local intranet

Start

CDVRc

SnagIt

Service Informati...

3:15 PM

CDVR PC Software

- This is the first screen to appear when starting the CDVR PC software application icon

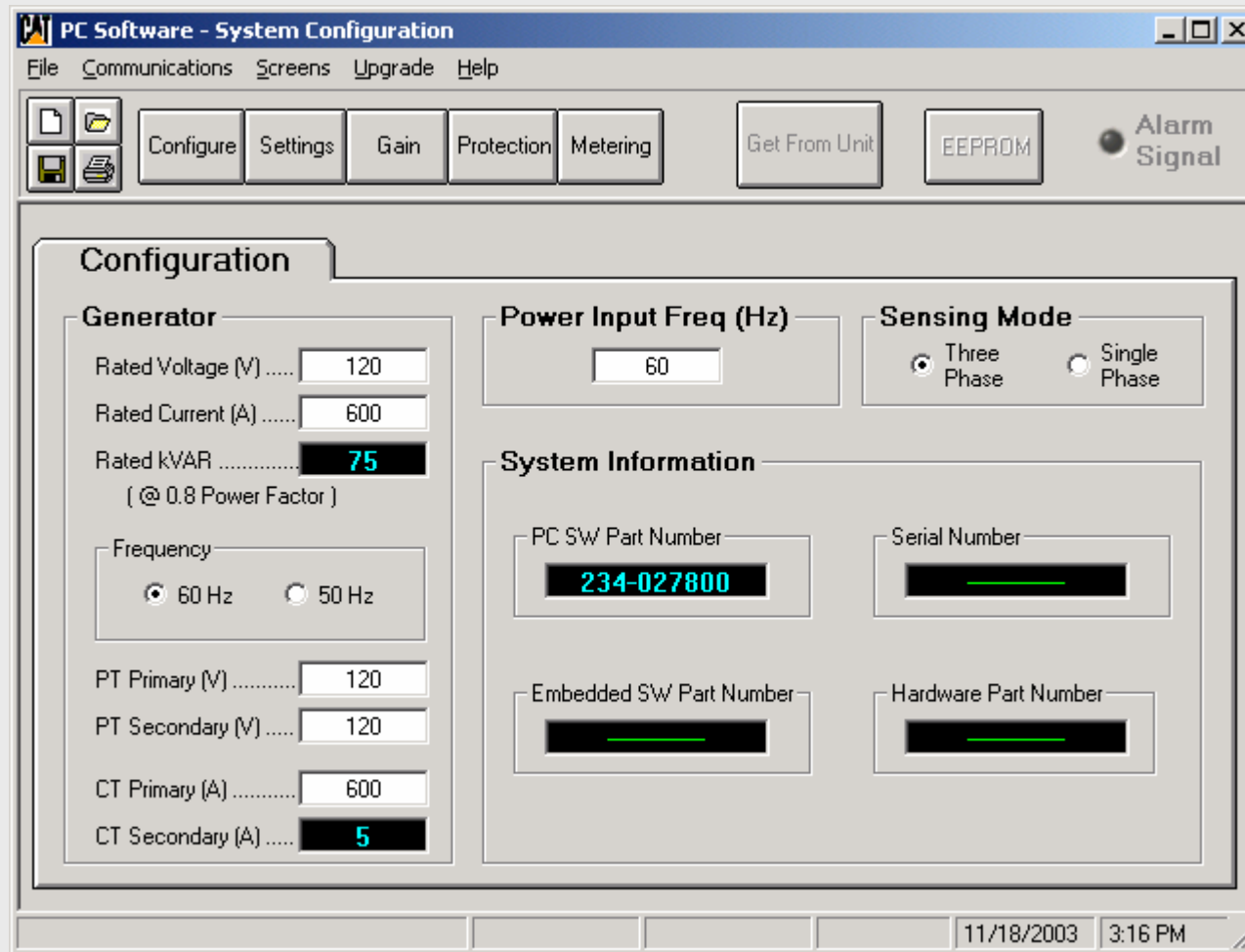

What's needed for communication?

1. Computer with the CDVR Software installed (the computer must meet the minimum requirements in the CDVR Service Manual)
2. Cable to connect the computer to the CDVR RS-232 port. Newer computers may not have an RS-232 port and may require a USB to RS-232 adapter. Cables are not provided.
3. 24VDC power to the CDVR input power connections. AC Sensing and/or PMG power voltage is not needed for communication.

Caterpillar Digital Voltage Regulator (CDVR) PC Software Overview

Prepared by Service Training

<https://psmktg.cat.com/srvtrng/>

CDVR Programming Overview

- The next few slides provide only a brief explanation of the CDVR PC Software screens and parameters. The CDVR Service Manual, RENR7941, should be referenced for more detail on the parameters and functions not covered in this overview.

CDVR Programming Overview

- “File” pull down menu is used to Open, Save or Print CDVR program configuration (*.DV2) files

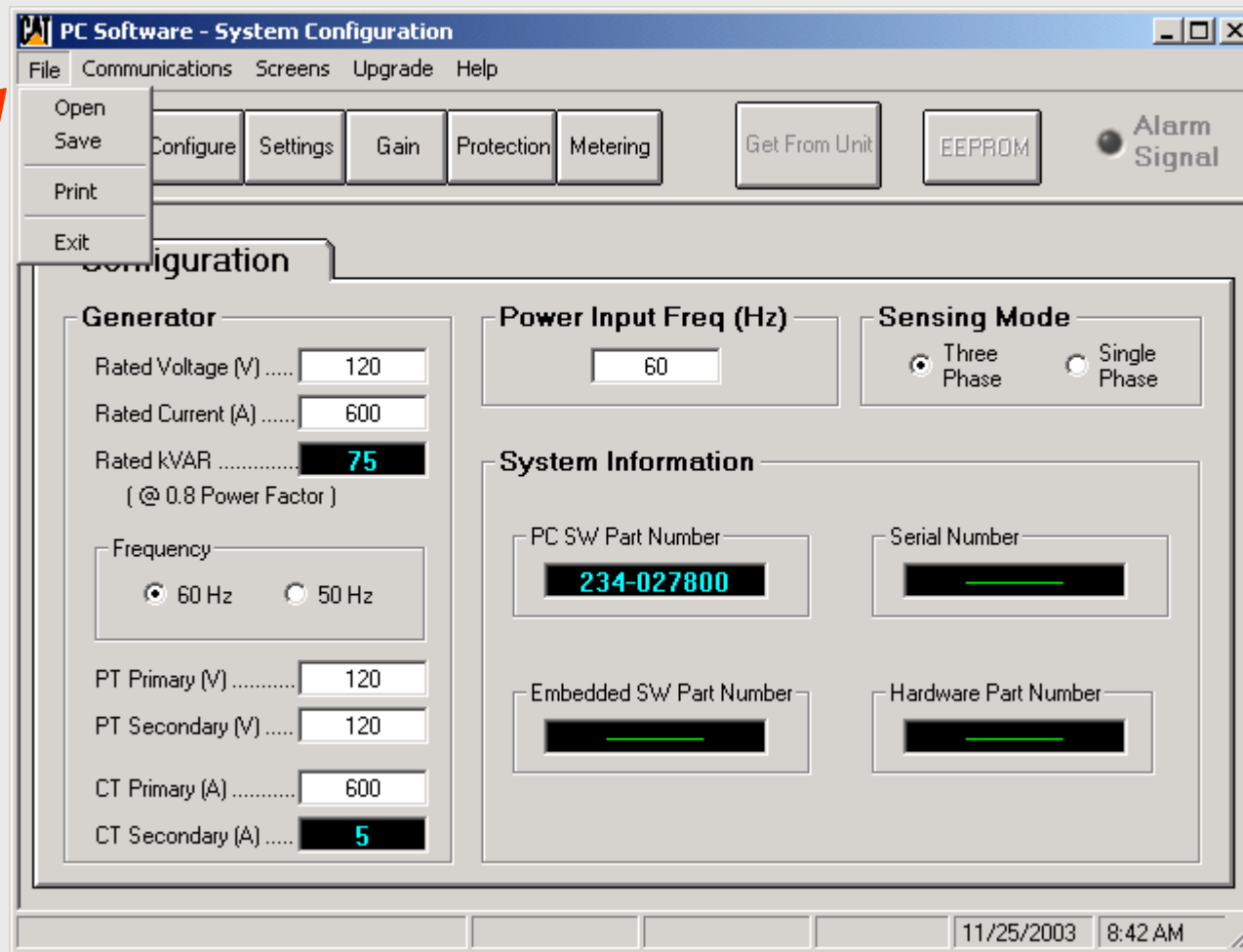

CDVR Programming Overview

- “Communications” pull down menu is used to connect or disconnect CDVR communication

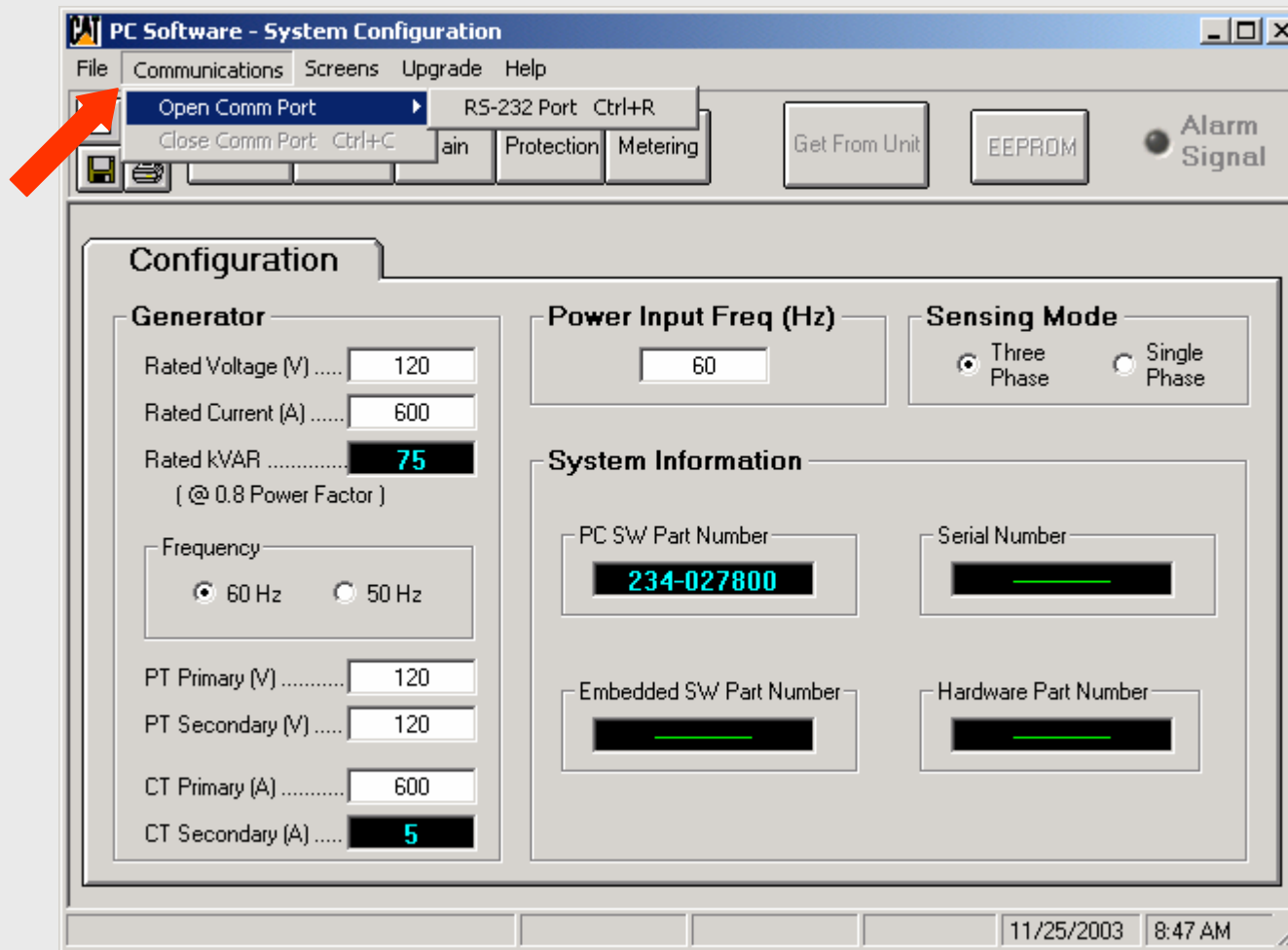

CDVR Programming Overview

- “Screens” pull down menu or the buttons are used to select the five configuration screens

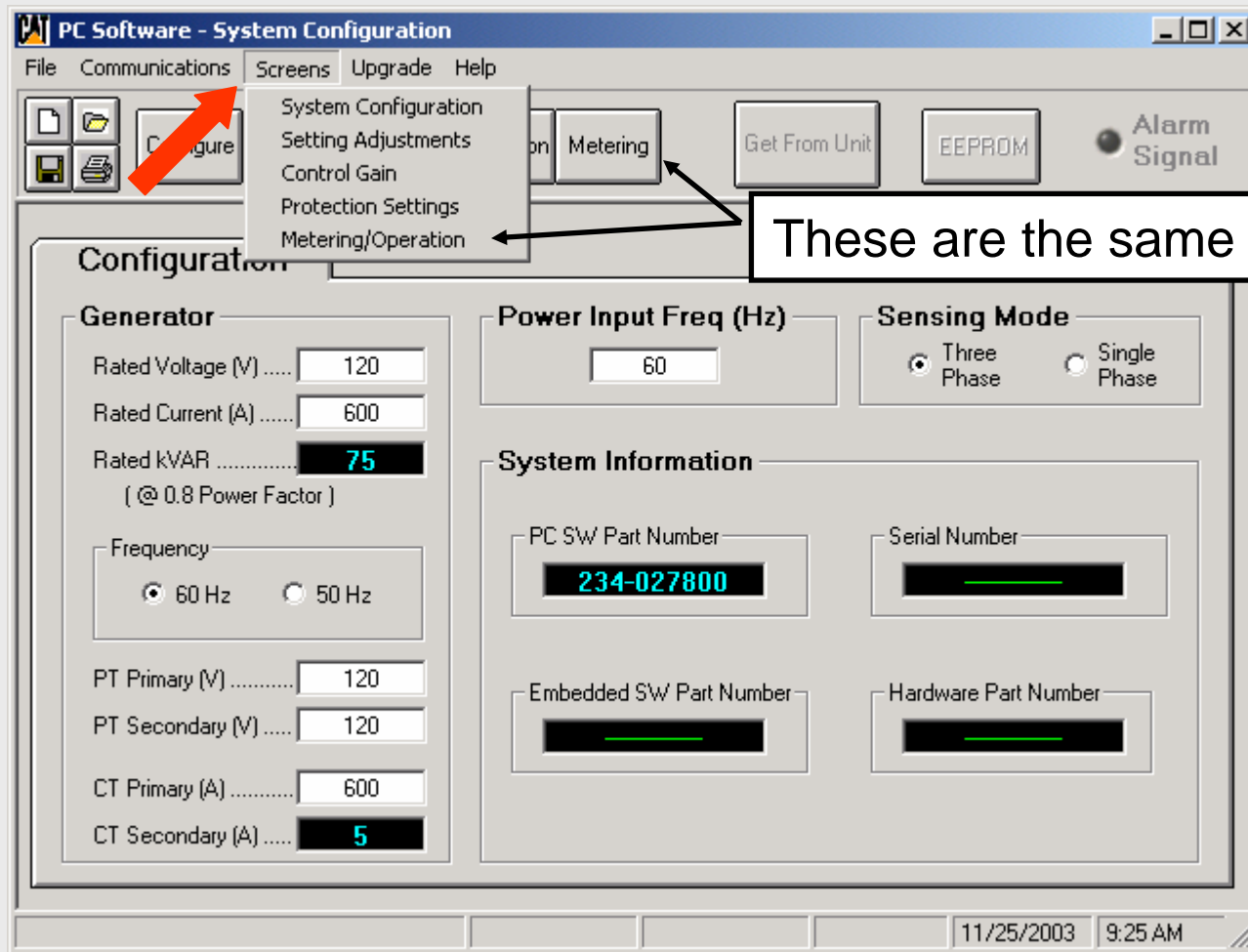

CDVR Programming Overview

- “Upgrade” pull down is not presently used but is for upgrading the CDVR embedded software

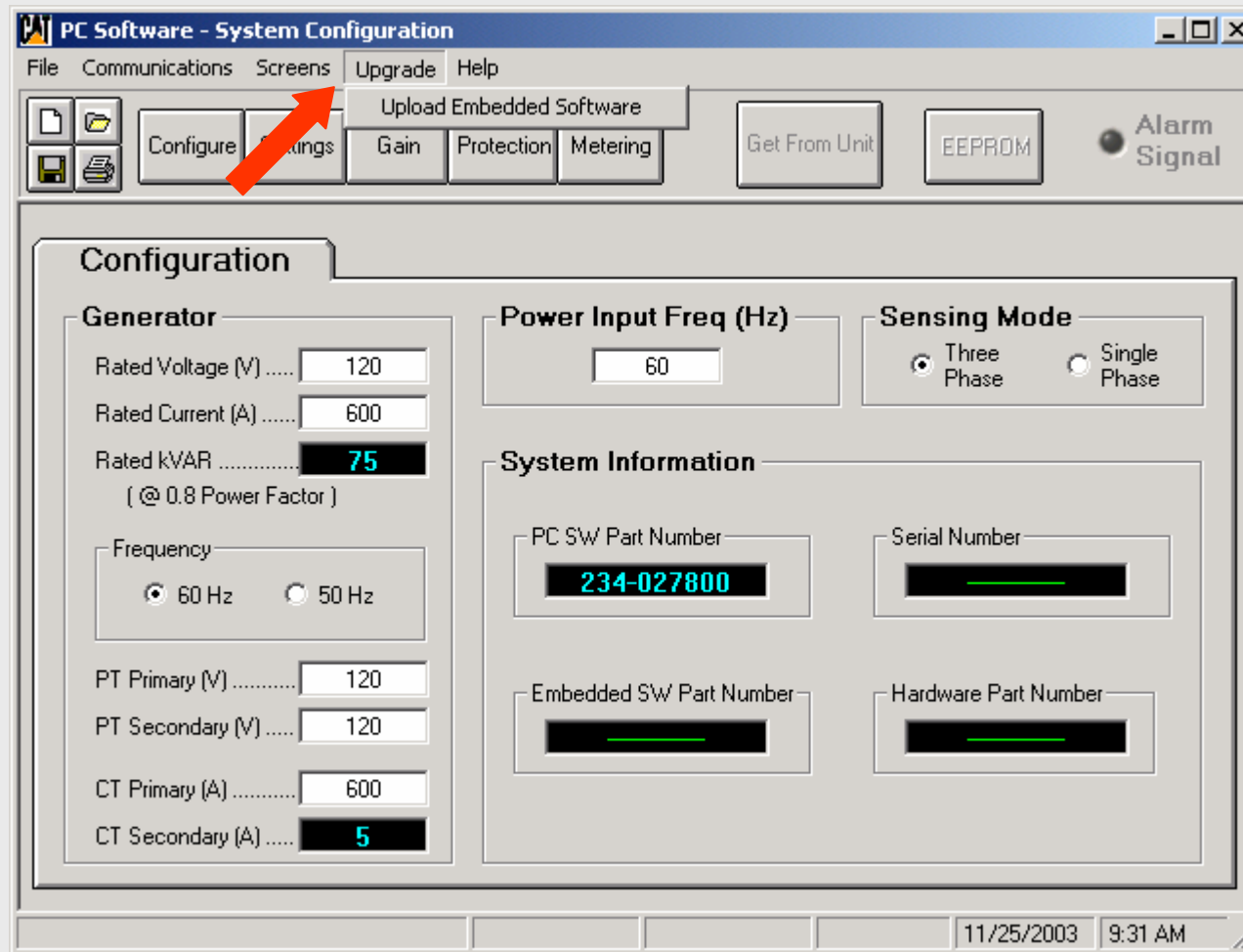

CDVR Programming Overview

- “Upgrade” pull down will display the version of PC Software being used. Also shown here.

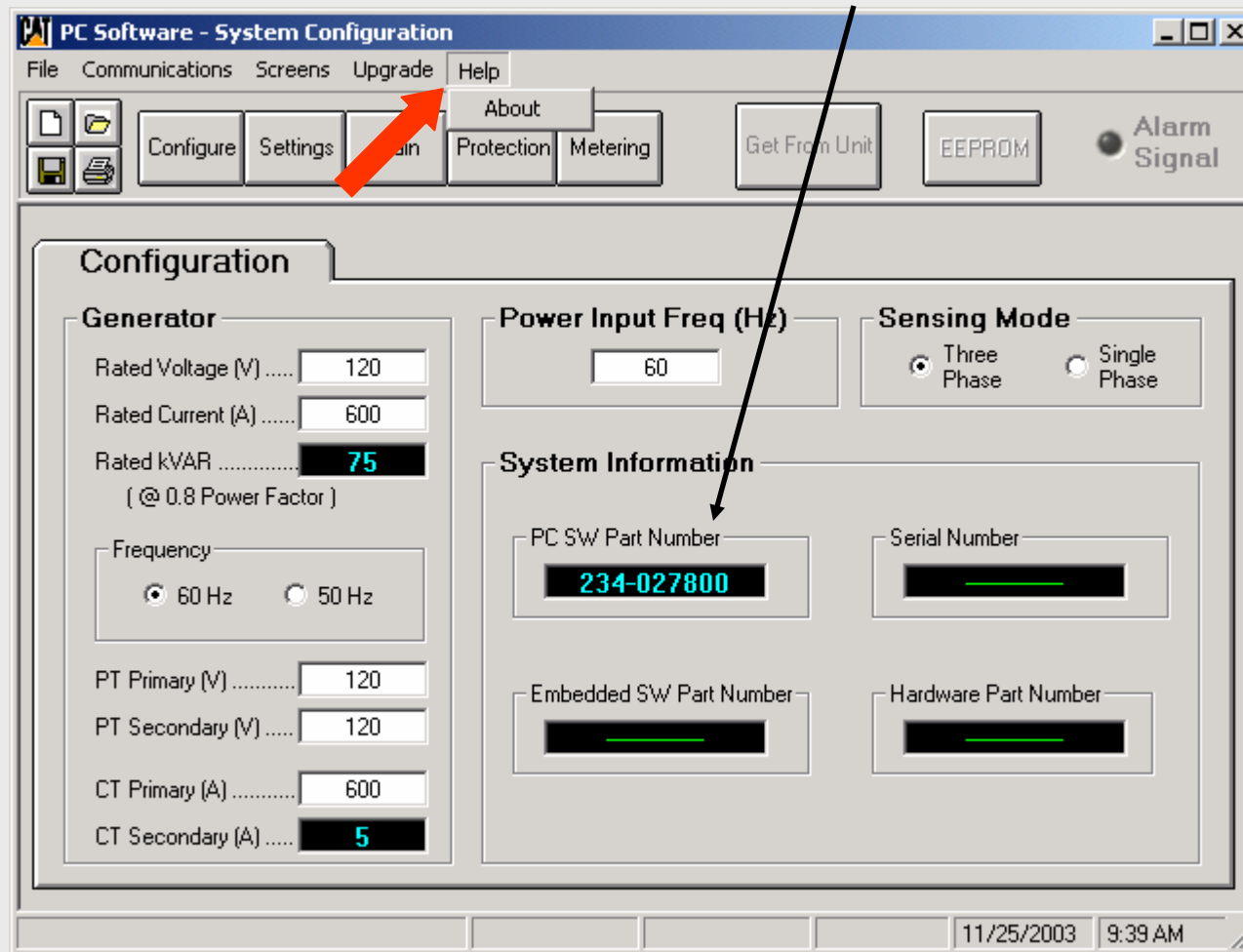

System Configuration Screen

- “Configuration” screen has generator voltage and current output and sensing parameters.

Only fields with a white background can be changed. In this case, “Rated Voltage” has been selected and is high lighted.

The bottom screen bars show the minumum, maximum and step or increment allowed for the selected parameter.

PC Software - System Configuration

File Communications Screens Upgrade Help

Configure Settings Gain Protection Metering Get From Unit EEPROM Alarm Signal

Configuration

Generator

Rated Voltage (V) 120

Rated Current (A) 600

Rated kVAR 75
(@ 0.8 Power Factor)

Frequency

60 Hz 50 Hz

PT Primary (V) 120

PT Secondary (V) 120

CT Primary (A) 600

CT Secondary (A) 5

Power Input Freq (Hz)

60

Sensing Mode

Three Phase Single Phase

System Information

PC SW Part Number 234-027800

Serial Number _____

Embedded SW Part Number _____

Hardware Part Number _____

Rated Generator Voltage Min: 90 Max: 15000 Step: 1 11/25/2003 9:45 AM

System Configuration Screen

- “Configuration” screen has generator voltage and current output and sensing parameters.

Rated voltage is changed from 120V to 240V by entering “240” and then the “Enter” key. Do not use the Tab key. When 240 is entered the Rated kVAR automatically changes from 75 to 150. Fields with a black background cannot be clicked on and changed.

PC Software - System Configuration

File Communications Screens Upgrade Help

Configure Settings Gain Protection Metering Get From Unit EEPROM Alarm Signal

Configuration

Generator

Rated Voltage (V) 240

Rated Current (A) 600

Rated kVAR 150
(@ 0.8 Power Factor)

Frequency

60 Hz 50 Hz

PT Primary (V) 120

PT Secondary (V) 120

CT Primary (A) 600

CT Secondary (A) 5

Power Input Freq (Hz)

60

Sensing Mode

Three Phase Single Phase

System Information

PC SW Part Number: 234-027800

Serial Number: _____

Embedded SW Part Number: _____

Hardware Part Number: _____

Rated Generator Voltage Min: 90 Max: 15000 Step: 1 11/25/2003 9:48 AM

System Configuration Screen

There are two operating frequency parameters.

“Power Input Freq” is the frequency of the input power. On SE this is the same as the generator operating frequency which is 50 or 60Hz only. For PMG is the frequency from the PMG exciter stator.

“Frequency” comes from the generator nameplate and will be 50 or 60 Hertz.

The screenshot shows the 'PC Software - System Configuration' window. The interface includes a menu bar (File, Communications, Screens, Upgrade, Help) and a toolbar with buttons for 'Configure', 'Settings', 'Gain', 'Protection', 'Metering', 'Get From Unit', and 'EEPROM'. An 'Alarm Signal' indicator is also present. The main configuration area is divided into several sections:

- Generator:** Includes fields for Rated Voltage (V) set to 240, Rated Current (A) set to 600, and Rated kVAR set to 150. A 'Frequency' section has radio buttons for 60 Hz (selected) and 50 Hz.
- Power Input Freq (Hz):** A field set to 60.
- Sensing Mode:** Radio buttons for Three Phase (selected) and Single Phase.
- System Information:** Fields for PC SW Part Number (234-027800), Serial Number, Embedded SW Part Number, and Hardware Part Number.
- Other Parameters:** PT Primary (V) and PT Secondary (V) are both set to 120. CT Primary (A) is set to 600, and CT Secondary (A) is set to 5.

At the bottom of the window, a status bar displays: Rated Generator Voltage, Min: 90, Max: 15000, Step: 1, 11/25/2003, 9:48 AM.

System Configuration Screen

Other sensing parameters explained

Sensing Mode can be Three or Single Phase

PT Primary and Secondary voltages

Droop CT is programmed to 600 on the primary, 5 on the secondary is not adjustable so the droop CT ratio is 600:5

The screenshot shows the 'PC Software - System Configuration' window. The 'Configuration' tab is active, displaying the following settings:

- Generator:**
 - Rated Voltage (V): 240
 - Rated Current (A): 600
 - Rated kVAR: 150 (@ 0.8 Power Factor)
 - Frequency: 60 Hz (selected), 50 Hz
 - PT Primary (V): 120
 - PT Secondary (V): 120
 - CT Primary (A): 600
 - CT Secondary (A): 5
- Power Input Freq (Hz):** 60
- Sensing Mode:** Three Phase (selected), Single Phase
- System Information:**
 - PC SW Part Number: 234-027800
 - Serial Number: [Redacted]
 - Embedded SW Part Number: [Redacted]
 - Hardware Part Number: [Redacted]

At the bottom of the window, the status bar shows: Rated Generator Voltage, Min: 90, Max: 15000, Step: 1, 11/25/2003, 9:48 AM.

System Configuration Screen

Get From Unit Button

Voltage regulator settings are retrieved by clicking the “Get From Unit” button. This causes the current settings of the CDVR to be displayed on the “settings” screen. This button will be grayed out until the communication is established.

Parameter changes are sent to the CDVR by pressing the Enter key on the PC or by selecting a setting from a pull-down menu. This causes the selected setting displayed on the setting screen to become the active voltage regulator setting.

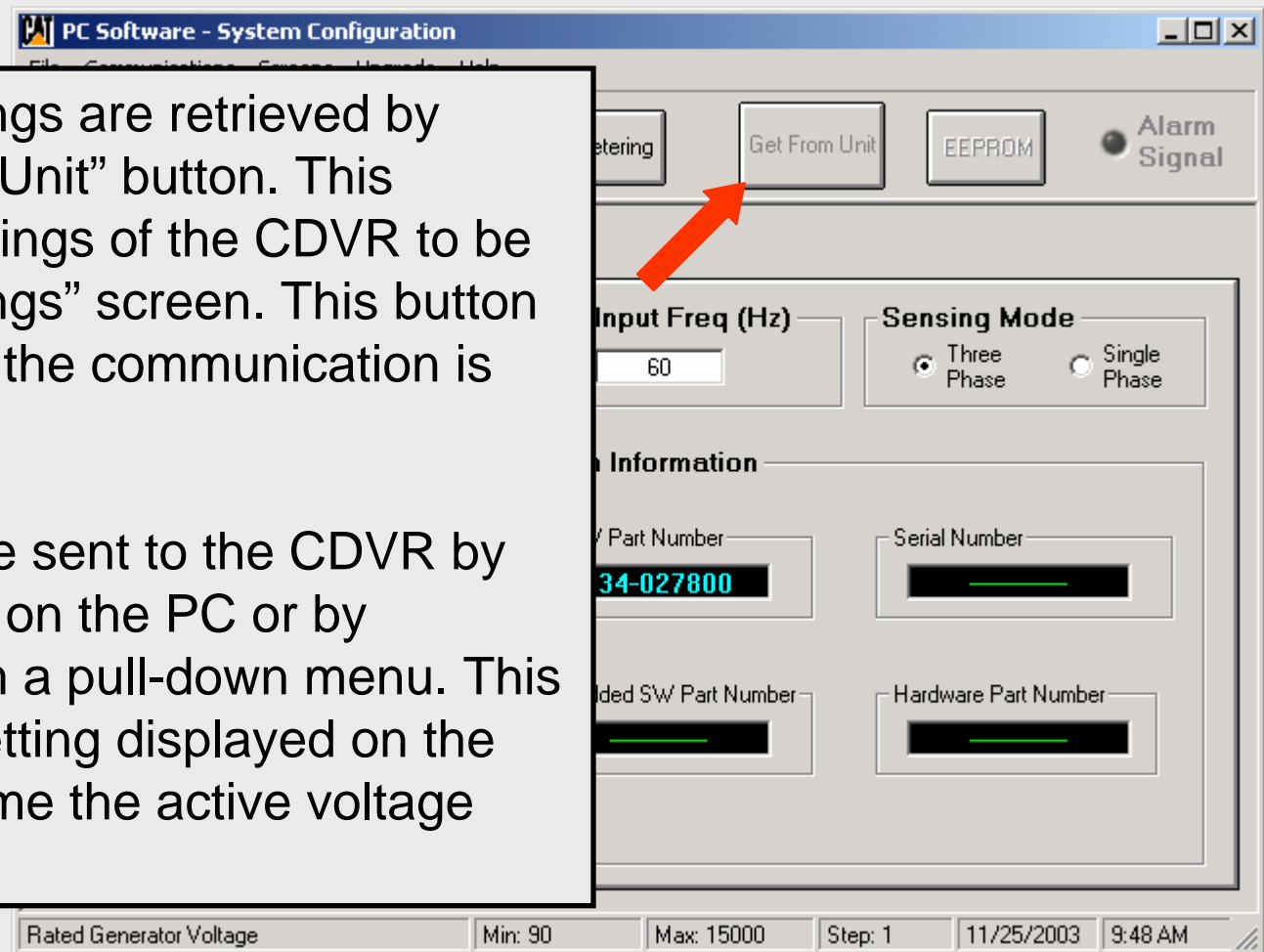

System Configuration Screen

EEPROM Button

Settings are saved in the CDVR EEPROM (nonvolatile memory). When power is removed, the EEPROM saved settings will be active at power-up. If the settings are changed and sent to the voltage regulator by hitting the enter key, they are not sent to the EEPROM. They will be lost if the CDVR is powered off. When closing communication the software will prompt the user to save the settings to the EEPROM. This question is asked even if no changes were made to the settings. While communicating the user can save changes to the EEPROM anytime by clicking the “EEPROM” button.

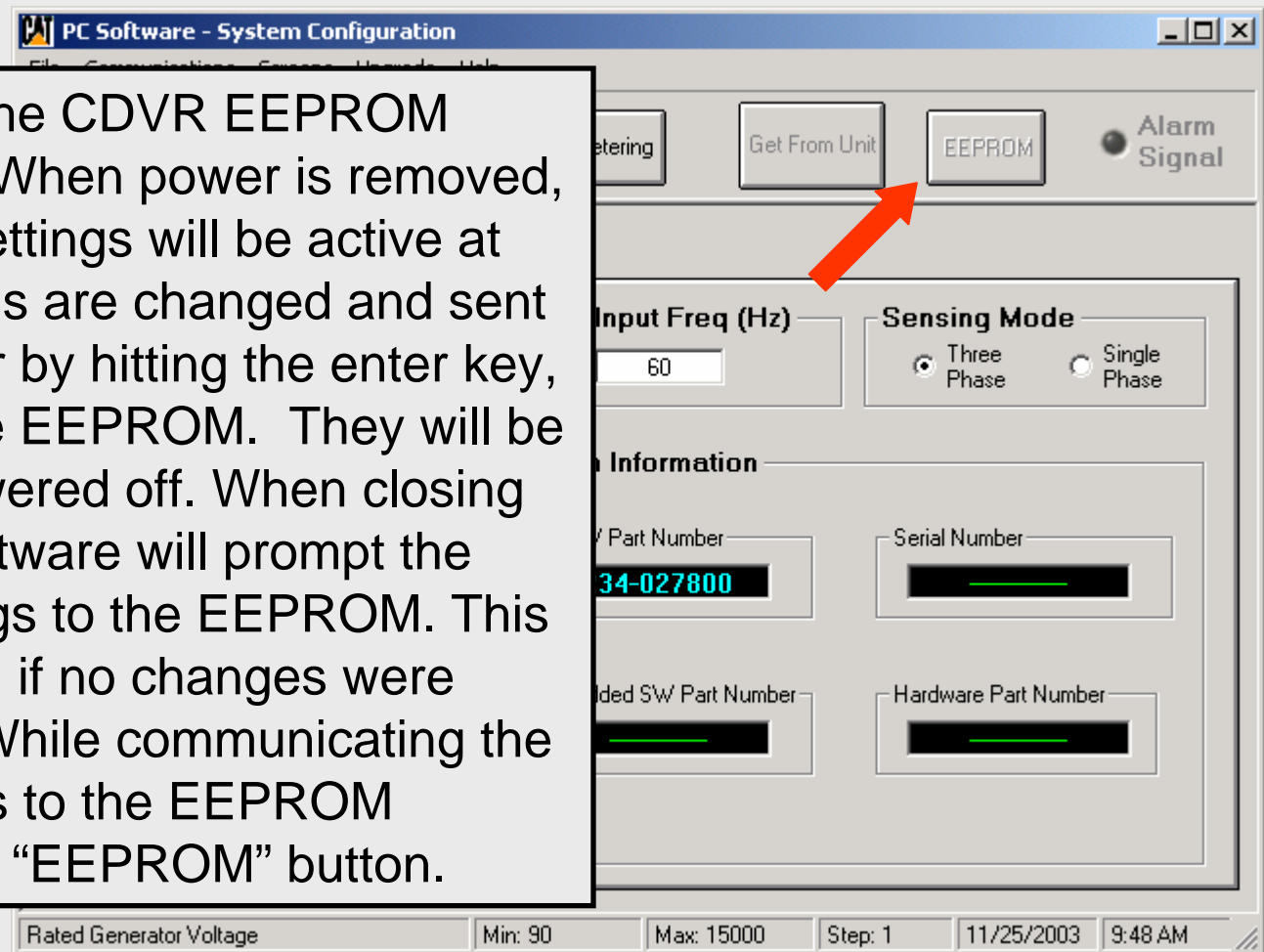

System Configuration Screen

Information for PC Software and CDVR

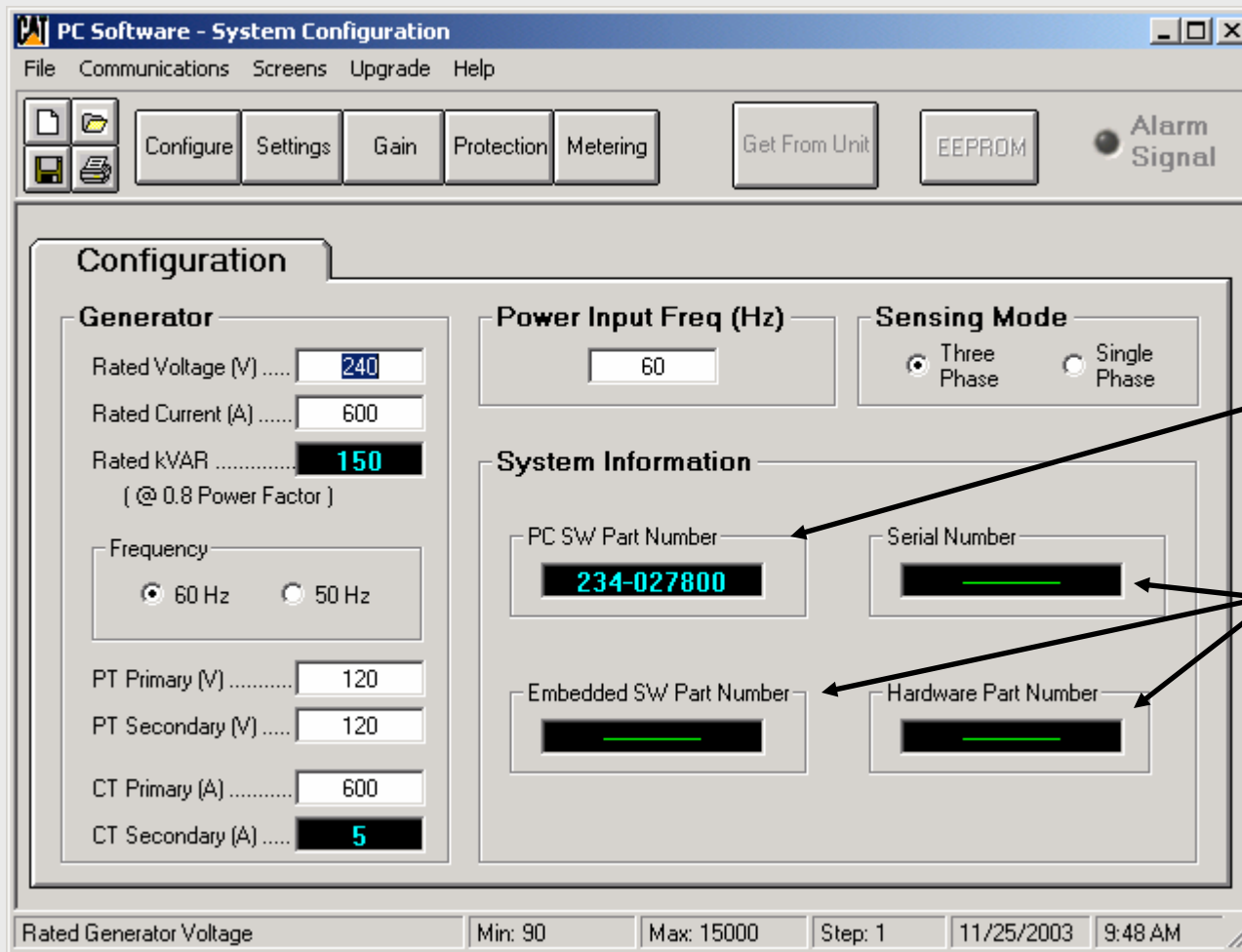

PC Software version

The CDVR serial number, internal embedded software version and CDVR part number will show in these three boxes

Setting Adjustments Screen

Setpoint Parameters

AVR Voltage is the terminal output voltage of the generator in the AVR mode.

VAR percentage sets VAR level maintained in the VAR mode.

Power Factor sets the PF maintained in the Power Factor mode.

The screenshot shows a software window titled "PC Software - Setting Adjustments" with a menu bar (File, Communications, Screens, Upgrade, Help) and a toolbar (Configure, Settings, Gain, Protection, Metering, Get From Unit, EEPROM, Alarm Signal). The main area has two tabs: "Setpoint" (selected) and "Startup".

Setpoint

AVR Voltage (V)	120.0
VAR (% of rated)	0.0
Overexcited (+)	
Underexcited (-)	
Power Factor	1.000
Lagging (+)	
Leading (-)	

Load Compensation Mode

Mode	Off
Setpoint (%)	0.00

Voltage Adjustment Band

(% of rated)	15.00
--------------------	-------

At the bottom right, the date and time are displayed as 11/26/2003 8:49 AM.

Setting Adjustments Screen

Setpoint Parameters

Load Compensation Mode settings are “Off, Droop, or Line Droop”. “Off” is no voltage droop. “Droop” allows up to 10% droop at full load. “Line Droop” allows voltage to increase up to 10% for line loss compensation.

The Setpoint (%) for “Droop” and “Line Droop” is 0 to 10%.

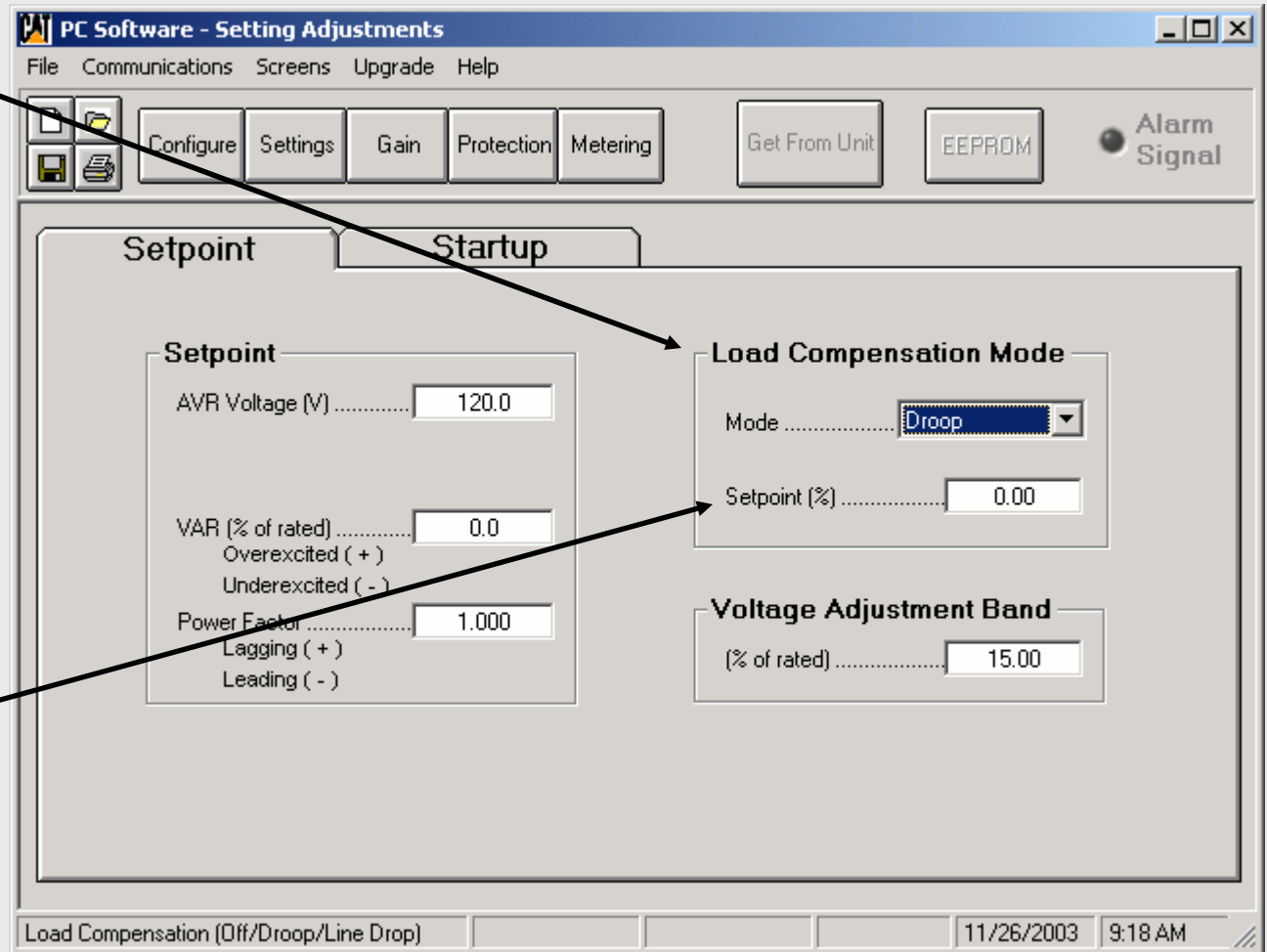

Setting Adjustments Screen

Startup Parameters Soft Start Mode

Soft Start Bias (%) determines the generator voltage offset during startup. 0 to 90 may be entered.

Soft Start Time (sec) establishes the length of time for the generator voltage to increase to the rated level. 0 to 120 sec. may be entered.

The screenshot shows a software window titled "PC Software - Setting Adjustments" with a menu bar (File, Communications, Screens, Upgrade, Help) and a toolbar with buttons for "Configure", "Settings", "Gain", "Protection", "Metering", "Get From Unit", and "EEPROM". There is also an "Alarm Signal" indicator. The main area is divided into "Setpoint" and "Startup" tabs. The "Startup" tab is active and contains two sections: "Soft Start Mode" and "Under Frequency Mode".

Parameter	Value
Soft Start Bias (%)	10.00
Soft Start Time (sec)	10.00
Knee Frequency (Hz)	50.00
Freq. Dev. from Knee Freq. (Hz)	5.00
Slope # 1 (V/Hz)	2.00
Slope # 2 (V/Hz)	2.00
Minimum Voltage (% of rated)	50.00
Minimum Frequency (Hz)	25.00

Setting Adjustments Screen

Startup Parameters Under Frequency Mode

The screenshot shows a software window titled "PC Software - Setting Adjustments" with a menu bar (File, Communications, Screens, Upgrade, Help) and a toolbar with buttons for Configure, Settings, Gain, Protection, Metering, Get From Unit, and EEPROM. An "Alarm Signal" indicator is also present. The main area is divided into "Setpoint" and "Startup" tabs. The "Startup" tab is active, showing two sub-sections: "Soft Start Mode" and "Under Frequency Mode". The "Under Frequency Mode" section is highlighted with a black box and an arrow pointing to it from the text on the right. The parameters in the "Under Frequency Mode" section are:

Parameter	Value
Knee Frequency (Hz)	50.00
Freq. Dev. from Knee Freq. (Hz)	5.00
Slope # 1 (V/Hz)	2.00
Slope # 2 (V/Hz)	2.00
Minimum Voltage (% of rated)	50.00
Minimum Frequency (Hz)	25.00

The "Soft Start Mode" section contains:

Parameter	Value
Soft Start Bias (%)	10.00
Soft Start Time (sec)	10.00

The status bar at the bottom shows the date 11/26/2003 and time 9:19 AM.

The five programmable Under Frequency Mode parameters determine the CDVR under frequency voltage regulation characteristic curve.

The next slide has a graph of the under frequency voltage regulation characteristic curve and setpoints.

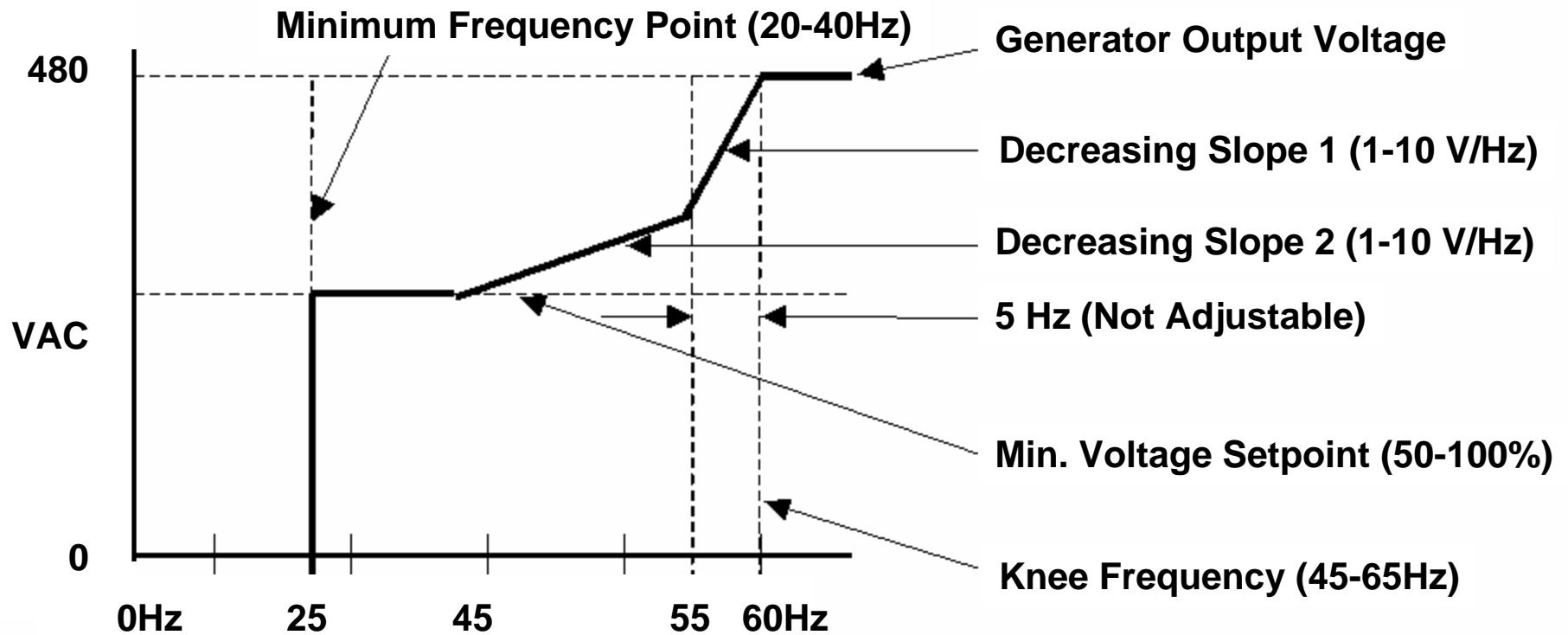

Regulation Characteristic. Below the **Knee Frequency**, the generator voltage follows a decreasing slope based on generator frequency. When generator frequency is between the Knee Frequency and Knee Frequency minus 5 hertz, voltage follows **Slope 1**. When generator frequency is between the Knee Frequency minus 5 hertz and the Underfrequency Point, voltage follows **Slope 2** down to the **Minimum Voltage Setpoint**. When generator frequency is below the **Minimum Frequency Point**, excitation is removed. Programming Decreasing Slope 2 is optional.

Control Gain Screen

Control Gain

Generators delivered with a CDVR installed will have these parameters set for optimal generator operation. These settings may vary on different packages.

These parameters are covered in detail in the Service Manual and it should be referenced when making changes.

The screenshot shows a software window titled "PC Software - Control Gain" with a menu bar (File, Communications, Screens, Upgrade, Help) and a toolbar with buttons for "Configure", "Settings", "Gain", "Protection", "Metering", "Get From Unit", and "EEPROM". An "Alarm Signal" indicator is also present. The main area is titled "Control Gain" and contains a "PID Pre-Settings" section with a dropdown menu showing "(Custom PID Settings...)" and a blue "PID" button. Below this are two columns of parameters:

Parameter	Value
Proportional Gain Kp	200.00
Integral Gain Ki	600.00
Derivative Gain Kd	30.00
Noise Filter Time Constant Td	0.00
Loop Gain Kg	50.00

Parameter	Value
VAR Integral Gain Ki	5.00
VAR Loop Gain Kg	2.50
PF Integral Gain Ki	5.00
PF Loop Gain Kg	3.00

The status bar at the bottom shows "PID Calculator", "11/26/2003", and "10:46 AM".

Protection Settings Screen

Protection

This screen has the parameters for setting Generator protection.

The Shutdown Override button can be toggled from DISABLED to ENABLED during set-up or troubleshooting.

If the Fault Reset Switch is held too long the CDVR will take programmed action.

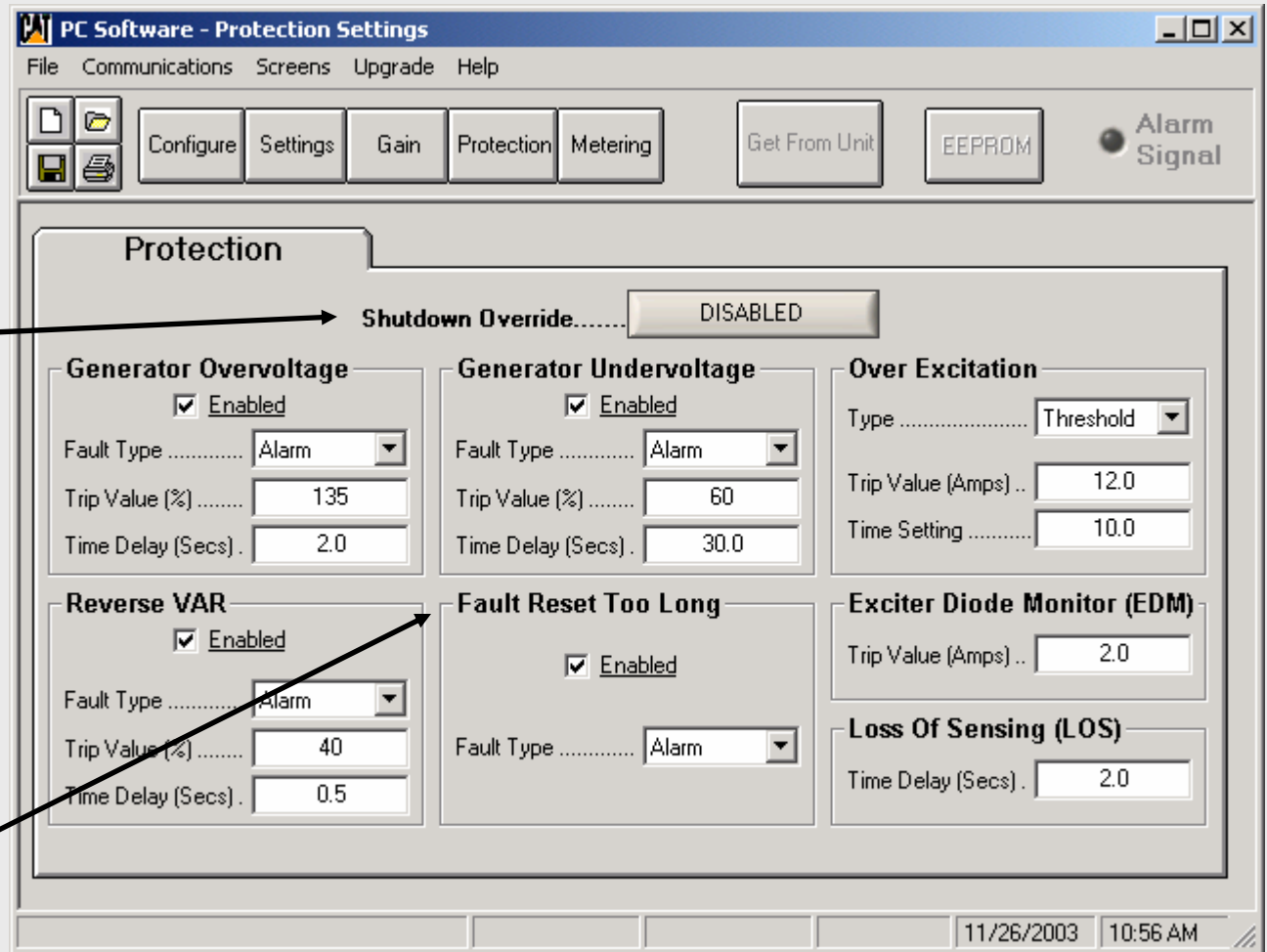

Protection Settings Screen

Protection

Protective settings like Generator Overvoltage have the following:

1. Enable check box,
2. Fault Type (Alarm or Shutdown)
3. Trip Value (%)
4. Time Delay (Sec.)

If output voltage exceeds 135% for 2 seconds, an Alarm condition will activate.

The screenshot shows the 'PC Software - Protection Settings' window. The 'Protection' tab is active, and the 'Shutdown Override' is set to 'DISABLED'. The settings are organized into several panels:

- Generator Overvoltage:** Enabled (checked), Fault Type: Alarm, Trip Value (%): 135, Time Delay (Secs): 2.0.
- Generator Undervoltage:** Enabled (checked), Fault Type: Alarm, Trip Value (%): 60, Time Delay (Secs): 30.0.
- Over Excitation:** Type: Threshold, Trip Value (Amps): 12.0, Time Setting: 10.0.
- Reverse VAR:** Enabled (checked), Fault Type: Alarm, Trip Value (%): 40, Time Delay (Secs): 0.5.
- Fault Reset Too Long:** Enabled (checked), Fault Type: Alarm.
- Exciter Diode Monitor (EDM):** Trip Value (Amps): 2.0.
- Loss Of Sensing (LOS):** Time Delay (Secs): 2.0.

The status bar at the bottom right shows the date 11/26/2003 and time 10:56 AM.

Protection Settings Screen

Protection

PC Software - Protection Settings

File Communications Screens Upgrade Help

Configure Settings Gain Protection Metering Get From Unit EEPROM Alarm Signal

Protection

Shutdown Override..... DISABLED

Generator Overvoltage
 Enabled
Fault Type Alarm
Trip Value (%) 135
Time Delay (Secs) . 2.0

Generator Undervoltage
 Enabled
Fault Type Alarm
Trip Value (%) 60
Time Delay (Secs) . 30.0

Over Excitation
Type Threshold
Trip Value (Amps) .. 12.0
Time Setting 10.0

Reverse VAR
 Enabled
Fault Type Alarm
Trip Value (%) 40
Time Delay (Secs) . 0.5

Fault Reset Too Long
 Enabled
Fault Type Alarm

Exciter Diode Monitor (EDM)
Trip Value (Amps) .. 2.0

Loss Of Sensing (LOS)
Time Delay (Secs) . 2.0

11/26/2003 10:56 AM

Excitation (Exciter Stator) current is monitored and if the programmed limits are exceeded the excitation current will be disabled.

Excitation current will also be disabled if the Exciter Diode Monitor or Loss of Sensing limits are exceeded.

Metering, Operation and Alarms Screen

Metering Password

When the “Metering” button is clicked a password prompt window opens.

This screen has password protection to prohibit an untrained person from changing parameters which may cause damage to the generator or force the generator into an unsafe operating mode.

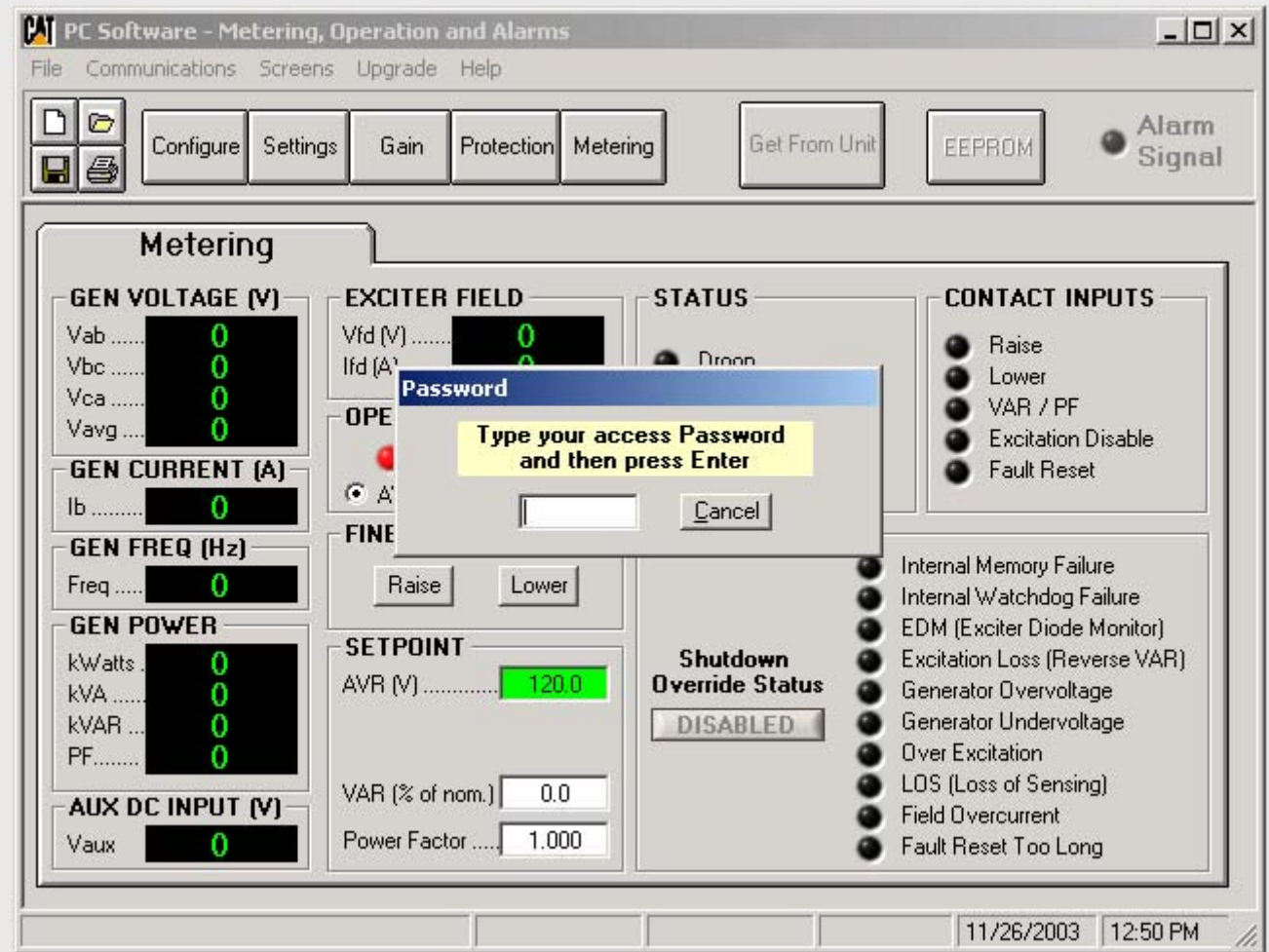

Metering, Operation and Alarms Screen

Metering Password

When the password “cat” is entered, full access is granted.

If “Cancel” is selected the Metering data is available only for viewing. Fields with white backgrounds cannot be changed and the soft buttons will be inactive.

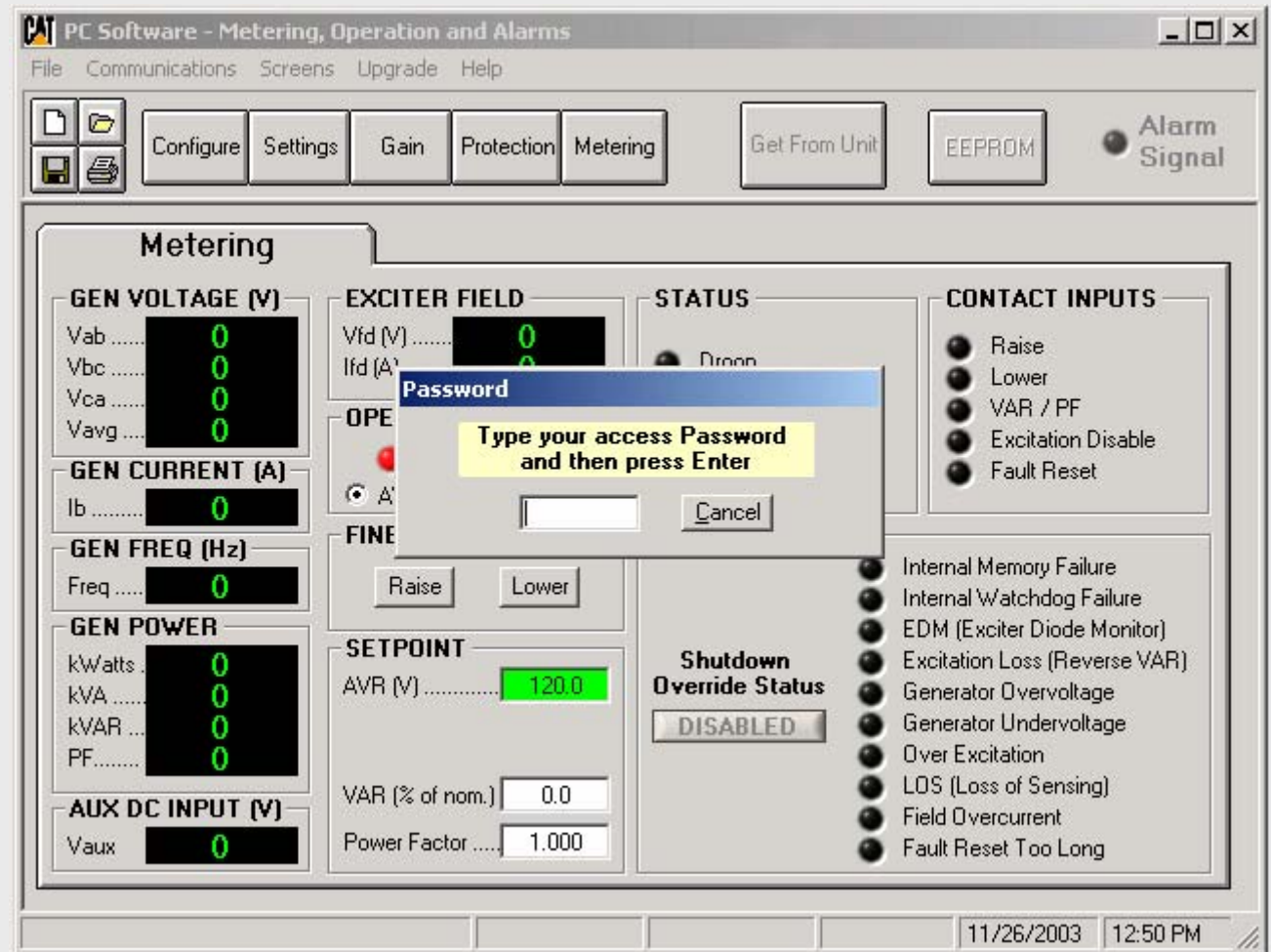

Metering, Operation and Alarms Screen

Metering

Generator operating parameters values are displayed in green.

Operating Mode is AVR and can be changed to VAR or PF.

Fine Adjustment acts as the raise/lower switch and varies the voltage level in AVR mode. This would vary VARs if in the VAR mode.

The screenshot shows the 'Metering, Operation and Alarms' software interface. The window title is 'PC Software - Metering, Operation and Alarms'. The menu bar includes 'File', 'Communications', 'Screens', 'Upgrade', and 'Help'. Below the menu bar are buttons for 'Configure', 'Settings', 'Gain', 'Protection', 'Metering', 'Get From Unit', and 'EEPROM'. An 'Alarm Signal' indicator is present. The main area is divided into several sections: 'Metering' (GEN VOLTAGE (V), GEN CURRENT (A), GEN FREQ (Hz), GEN POWER, AUX DC INPUT (V)), 'EXCITER FIELD' (Vfd (V), Ifd (A)), 'OPERATING MODE' (AVR, VAR, PF), 'FINE ADJUSTMENT' (Raise, Lower), 'SETPOINT' (AVR (V), VAR (% of nom.), Power Factor), 'STATUS' (Droop, Line Drop, Under Frequency, Soft Start), 'CONTACT INPUTS' (Raise, Lower, VAR / PF, Excitation Disable, Fault Reset), and 'ALARMS' (Internal Memory Failure, Internal Watchdog Failure, EDM (Exciter Diode Monitor), Excitation Loss (Reverse VAR), Generator Overvoltage, Generator Undervoltage, Over Excitation, LOS (Loss of Sensing), Field Overcurrent, Fault Reset Too Long). A 'Shutdown Override Status' button is labeled 'DISABLED'. The bottom right corner shows the date '11/26/2003' and time '1:07 PM'. All numerical values in the 'Metering' and 'SETPOINT' sections are displayed in green.

Metering, Operation and Alarms Screen

Metering

Setpoint allows the user to change the VAR or PF level to be maintained while the generator is operating.

Caution: While the generator running, the CDVR will immediately change its regulation to obey the values or buttons changed on this screen. Customer access is discouraged.

The screenshot displays the 'Metering, Operation and Alarms' software interface. The window title is 'PC Software - Metering, Operation and Alarms'. The menu bar includes 'File', 'Communications', 'Screens', 'Upgrade', and 'Help'. The toolbar contains icons for file operations and buttons for 'Configure', 'Settings', 'Gain', 'Protection', 'Metering', 'Get From Unit', and 'EEPROM'. An 'Alarm Signal' indicator is present. The main display area is divided into several sections: 'Metering' (GEN VOLTAGE (V), GEN CURRENT (A), GEN FREQ (Hz), GEN POWER, AUX DC INPUT (V)), 'EXCITER FIELD' (Vfd (V), Ifd (A)), 'OPERATING MODE' (AVR, VAR, PF), 'FINE ADJUSTMENT' (Raise, Lower), 'SETPOINT' (AVR (V), VAR (% of nom.), Power Factor), 'STATUS' (Droop, Line Drop, Under Frequency, Soft Start), 'CONTACT INPUTS' (Raise, Lower, VAR / PF, Excitation Disable, Fault Reset), and 'ALARMS' (Internal Memory Failure, Internal Watchdog Failure, EDM (Exciter Diode Monitor), Excitation Loss (Reverse VAR), Generator Overvoltage, Generator Undervoltage, Over Excitation, LOS (Loss of Sensing), Field Overcurrent, Fault Reset Too Long). A 'Shutdown Override Status' button is set to 'DISABLED'. The status bar at the bottom shows the date '11/26/2003' and time '1:07 PM'.

Metering, Operation and Alarms Screen

Metering

“Status” will light the soft LED modes that apply when active.

“Contact Inputs” will light when switched inputs are activated.

“Alarms” will light when the alarm is active or if a shutdown has occurred due to an alarm. The hard wired reset switch will reset.

The screenshot displays the 'Metering, Operation and Alarms' software interface. The window title is 'PC Software - Metering, Operation and Alarms'. The interface includes a menu bar (File, Communications, Screens, Upgrade, Help), a toolbar with buttons for Configure, Settings, Gain, Protection, Metering, Get From Unit, and EEPROM, and an Alarm Signal indicator. The main display area is divided into several sections: GEN VOLTAGE (V) with sub-sections for Vab, Vbc, Vca, and Vavg; GEN CURRENT (A) with sub-section for Ib; GEN FREQ (Hz) with sub-section for Freq; GEN POWER with sub-sections for kWatts, kVA, kVAR, and PF; AUX DC INPUT (V) with sub-section for Vaux; EXCITER FIELD with sub-sections for Vfd (V) and Ifd (A); OPERATING MODE with radio buttons for AVR, VAR, and PF; FINE ADJUSTMENT with Raise and Lower buttons; SETPOINT with AVF (V) set to 120.0, VAR (% of nom.) at 0.0, and Power Factor at 1.000; STATUS with radio buttons for Droop, Line Drop, Under Frequency, and Soft Start; CONTACT INPUTS with radio buttons for Raise, Lower, VAR / PF, Excitation Disable, and Fault Reset; and ALARMS with a Shutdown Override Status button set to DISABLED and a list of alarm indicators including Internal Memory Failure, Internal Watchdog Failure, EDM (Exciter Diode Monitor), Excitation Loss (Reverse VAR), Generator Overvoltage, Generator Undervoltage, Over Excitation, LOS (Loss of Sensing), Field Overcurrent, and Fault Reset Too Long. The status bar at the bottom shows the date 11/26/2003 and time 1:07 PM.

Metering, Operation and Alarms Screen

Metering

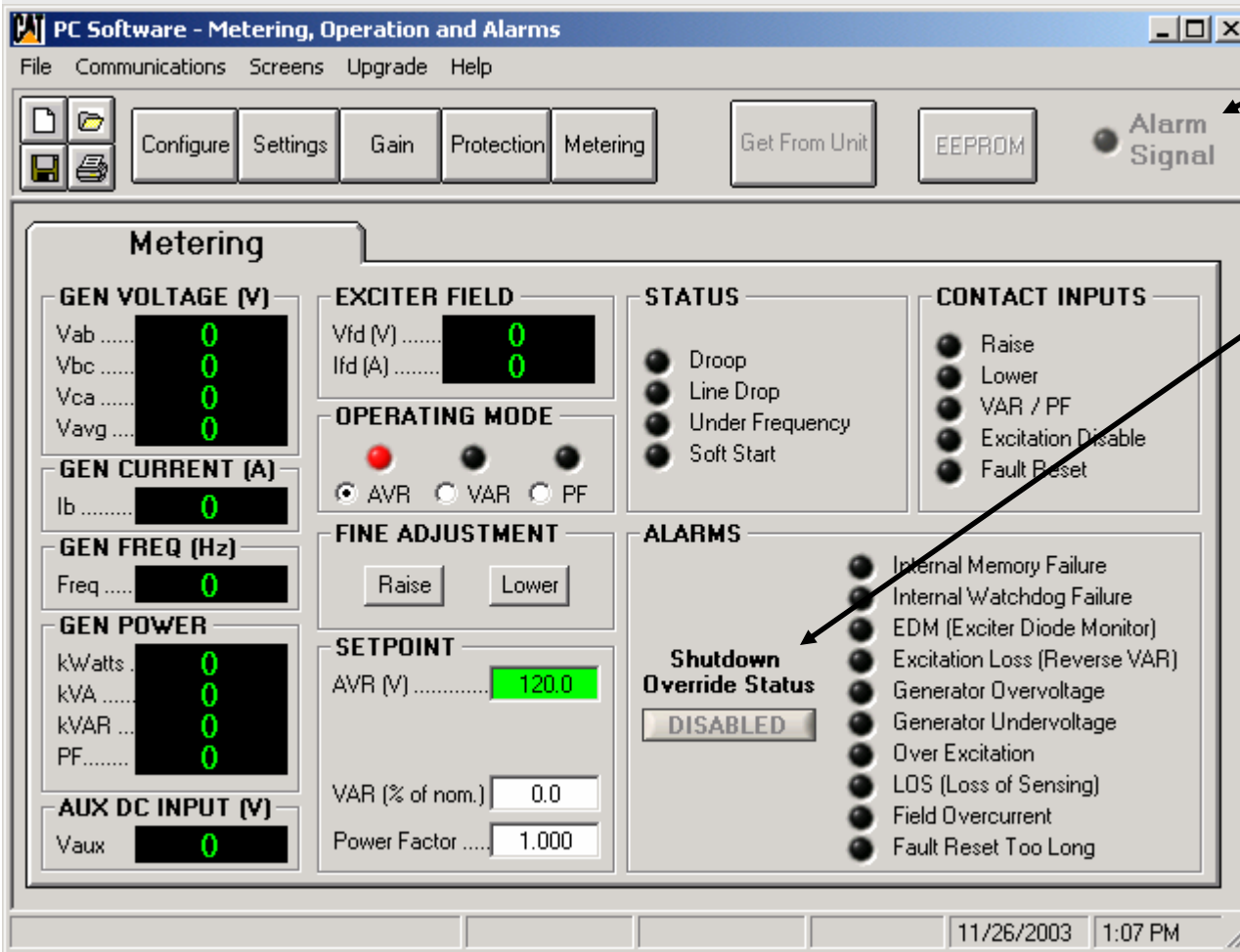

The “Alarm Signal” LED will light if there is an active alarm condition.

When the “Disabled” button is toggled to “Enabled” the CDVR will not allow normal shutdown faults to shutdown excitation for troubleshooting. This must used carefully to protect the generator from unsafe conditions.

Summary

This concludes the training overview of the CDVR. This presentation will be updated as needed and available on the Caterpillar Service Training Website at: <https://psmktg.cat.com/srvtrng/>

Again, the proper service information for the regulators in SIS should be used for the latest specific details for operation, adjustments, programming and troubleshooting. Please E-mail comments about this overview presentation to Todd Roth at roth_b_todd@cat.com. Thank You!

**CAT[®] Electric
Power**